

Operating Instructions

Serial Impact Dot Matrix Printer

DMX80UK

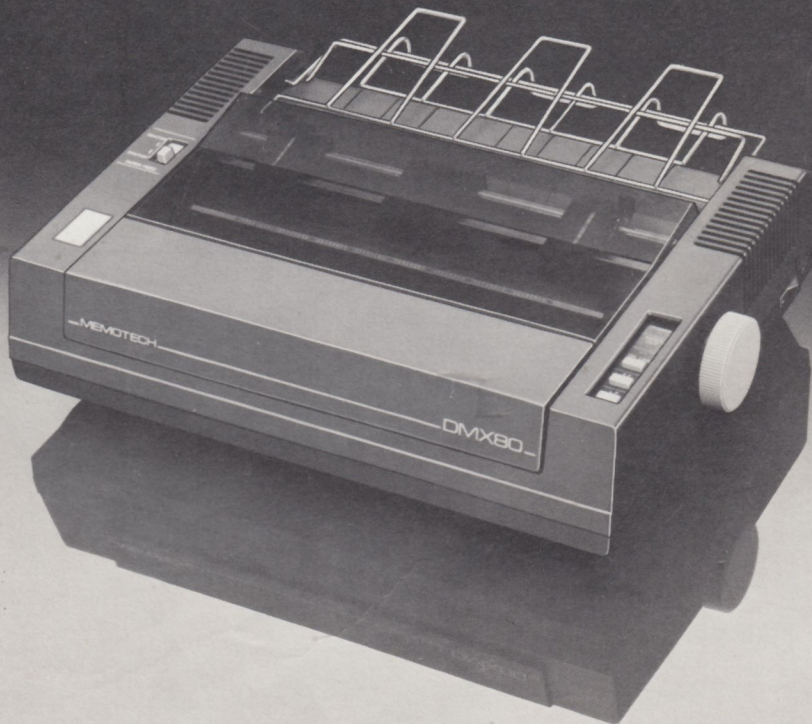

MEMOTECH

Thank you very much for having purchased this Serial Dot Matrix Printer, DMX80UK.

Before operating this unit read through these Operating Instructions to familiarize yourself with the functions of the unit.

This will enable you to enjoy the maximum benefit from your printer.

This printer is primarily designed to be used with general personal computers, and smaller business computers.

Any details given in these Operating Instructions are subject to change without notice.

WARNING: TO PREVENT FIRE OR SHOCK HAZARD, DO NOT EXPOSE THIS PRODUCT TO RAIN OR ANY TYPE OF MOISTURE.

The serial number of the unit may be found on the label on the bottom of the unit. For your convenience, note this number below, and retain this book, along with your proof of purchase, to serve as a permanent record of your purchase in the event of a theft, or for future reference.

MODEL NO. DMX80UK NAME OF DEALER _____

SERIAL NO. _____ DATE OF PURCHASE _____

CONTENTS

1	FEATURES	6
2	PRECAUTIONS	6
3	PARTS SUPPLIED	7
4	INSTALLATION	7
	1. Reminders	7
	2. General procedure	7
	3. Attachment and mounting	8
	A Removing the printer covers	8
	B Removing the carriage clamp	8
	C Mounting the ribbon cassette	8
	D Connecting the power cord	9
	E Mounting the paper separators	10
	F Mounting the paper	10
	G Adjusting the distance between the printing head and platen	14
	H Installing the paper	14
	I Fitting the covers into position	15
	J Aligning the top of form position	16
5	FUNCTIONS	
	1. Switches	17
	2. Self test printing	17
	3. Indicators	17
	4. Out-of-paper detector and other functions	18
	5. Initial mode and DIP switch	18
6	INTERFACE	20
	1. Connector	20
	2. Connector pin configuration	20
	3. Connector pin signals	21
7	CONTROL CODE	
	1. Code table and printing samples	25
	A Code table	25
	B Printing samples	27
	2. Control codes	29
	3. Expansion control commands	31
	4. Mixing printing modes/printing pitches	40
8	PRINTING SPEED	41
9	PAPER	41
10	PAPER STORAGE AND MAINTENANCE	43
11	SPECIFICATIONS	47
12	APPENDIX (CODE TABLE AND COMMAND TABLE)	49

NAMES OF THE PARTS

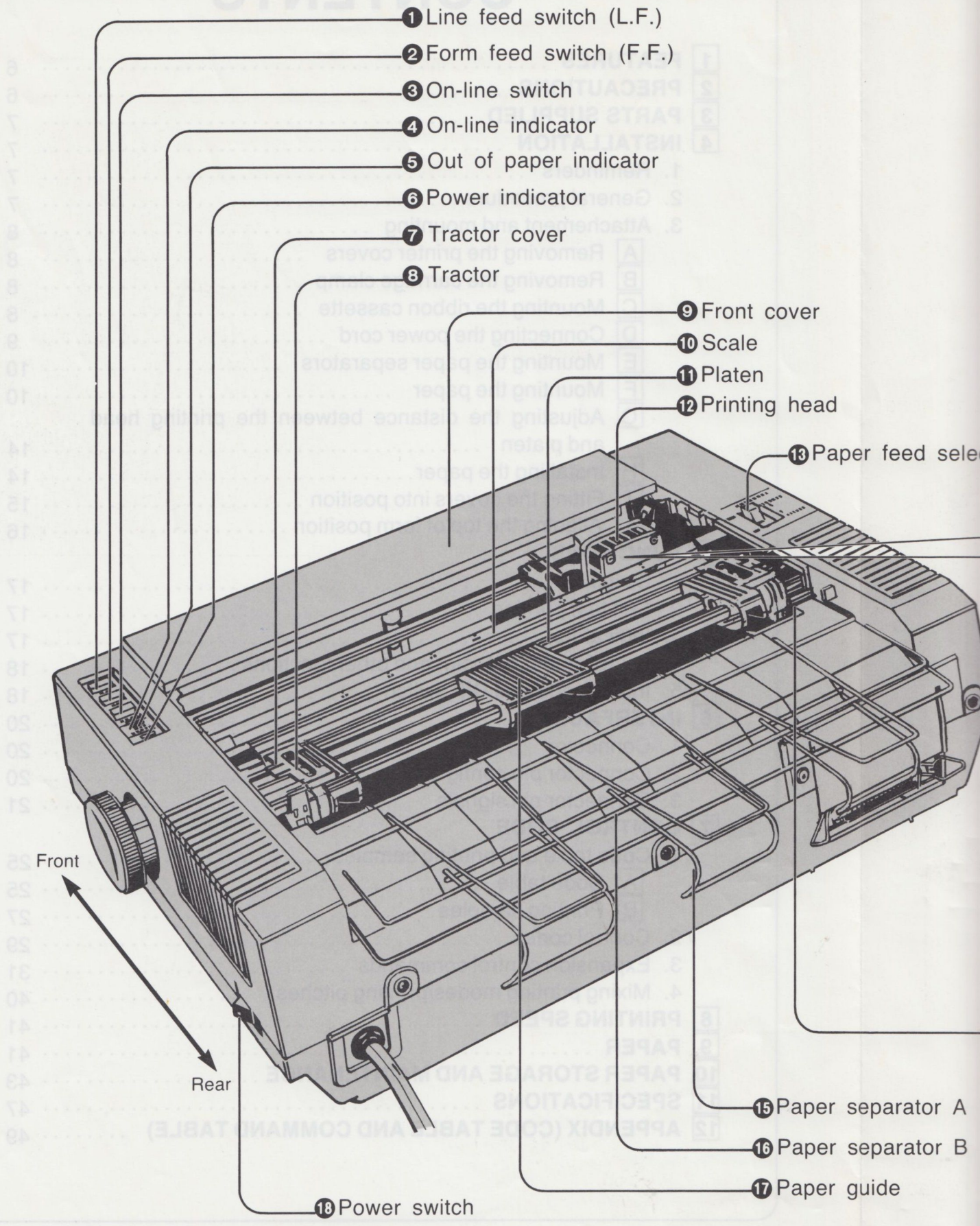

19 Sprocket hole

20 Printing head nose

21 Ribbon cassette

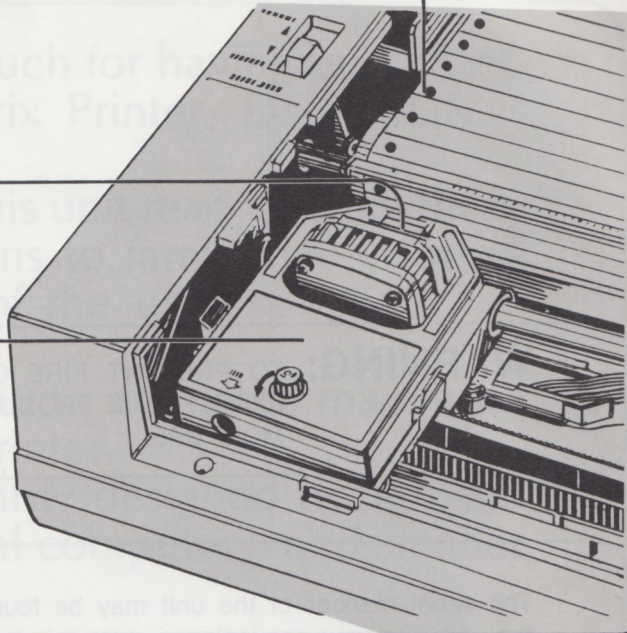

per feed selector

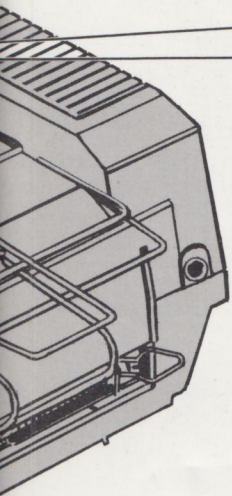

14 Tractor clamping lever

separator A
separator B
guide

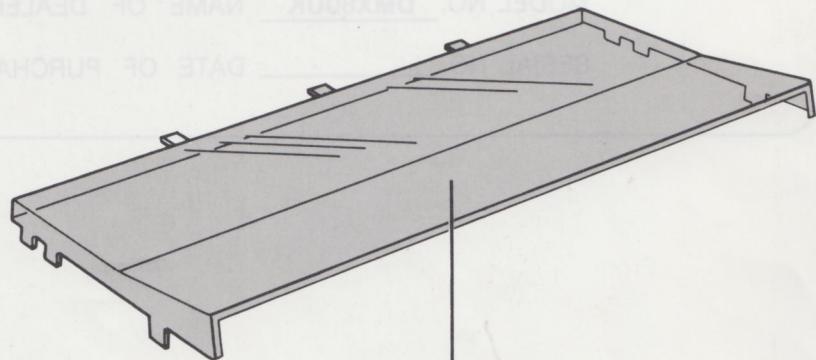

22 Top cover

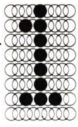

FEATURES

- (1) This printer employs an impact serial wire dot matrix printing system [3/254" (0.3 mm) dot diameter 9 pin system] to enable the printing of characters used in 8 different countries (United States, United Kingdom, France, West Germany, Italy, Spain, Sweden and Denmark), numbers, symbols, semi graphics, italics and graphic patterns.
- (2) Eighty (80) printed characters with the pica pitch can be accommodated per line with a printing speed of 80 characters/second.
- (3) The alignment of the top of form position can be set as desired by simply rotating a knob.
- (4) Font registry commands enable individual users to enter their own unique characters or symbols.
- (5) The seamless cartridge-type ribbon is designed for a long service life and easy replacement, and maintenance of a high printing quality. Its seamless, continuous surface provides a uniformly outstanding printing quality.
- (6) User-designated printing mode include:
 - double width character width is double.
 elongated
 - emphasis superimposed characters with
 a shift of 1/2 dot pitch hori-
 zontally.
 - superscript/
 subscript character dimensions of 299/
 3810" (1.99 mm) wide by
 489/9144" (1.36 mm) high.
 - underlining underlining capabilities on
 characters, numbers and
 symbols.
- (7) Two types of paper can be used with the printer: Continuous (Z-fold) paper with perforations at both sides, and letter paper.
- (8) This printer possesses both pica and elite pitch printing mode. Graphic printing (the ratio vertical: horizontal=1:1) is possible in elite pitch mode.

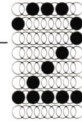

PRECAUTIONS

Water and foreign matter

It is dangerous to use this unit if any water or other liquids, needles, pins or other metal objects have found their way inside the printer. All foreign matter should be kept out of the unit. If any water or other liquids penetrate the inside of the unit, disconnect the power plug immediately and contact the dealer from whom you bought the unit.

Shocks

This unit is made with precision electronic components. Do not administer shocks to it by dropping or bumping it into objects, as this may result in malfunctioning.

Lengthy suspension of use

If you do not intend to use the unit for a prolonged period of time, disconnect the power cord from the power outlet.

Malfunctions

In the unlikely case of a malfunction, set the power switch to "off" and contact the dealer from whom you purchased the unit. Using the unit without proper repair work can increase the extent of the malfunction.

Dirt

Wipe away all dirt on the unit using a soft cloth or a cloth which has been dipped in detergent. Wiping the unit with benzene, thinners or other volatile solvents or spraying the unit with insecticide may change the color of the unit's paneling.

Printing head

- To prevent excessive wear on the printing head and platen, avoid using the unit for printing when the ribbon cassette and paper have not been installed.
- Do not use a cassette ribbon which is slack.
- Do not touch the printing head or apply unnecessary force to it while the unit is operational.
- Do not switch off the power while the printing head is operational.
- When printing underlining, semi graphic or bit images, avoid continuous usage of the same pin. (See underline designation command on page 33 and standard bit image designation command on page 37.)
- Do not touch a hot printing head.
- Do not touch the cable connected to the printing head as its service life can be reduced if distorted.

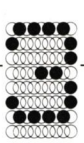

PARTS SUPPLIED

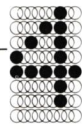

INSTALLATION

After unpacking the unit, check that all necessary parts have been included.

- (A) Ribbon cassette 1
- (B) Paper separators (A, B).....1 of each

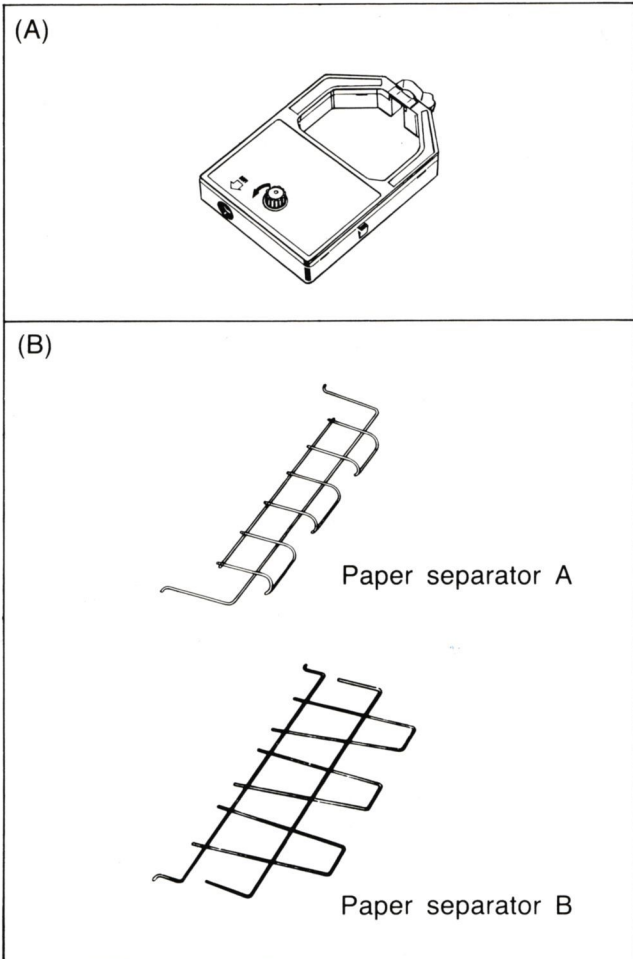

1. Reminders

Bear in mind the following points when installing the unit.

- Install the printer on a surface which is flat and horizontal, and not subject to vibration.
- Do not install the printer in a location exposed to direct sunlight or near a heater or any other such appliance.
- A clearance of at least about 4" (10 cm) between the side of the unit and wall or other surface to ensure proper ventilation.
- Do not use the unit in an excessively humid or moist location or in a location exposed to grease, metal fragments or dust.
- AC power should be supplied separately from that connected to an appliance (such as a large-sized motor) which generates noise.
- The right voltage should be supplied. Multifunctioning may result if the supply voltage is much higher or lower.
- While the printer is being used, its chassis will become hot due to the heat radiated by the transformer and motor. This is quite normal and not indicative of a malfunction.
- During printing operations the platen knob rotates. No subjects should obstruct this rotation (as this can damage the gears).

2. General procedure

Perform the following steps after having installed the unit:

- ① Remove the printer covers.
- ② Remove the carriage clamp.
- ③ Mount the ribbon cassette.
- ④ Connect the plug on the power cord to the AC outlet.
- ⑤ Mount the paper separators.
- ⑥ Set the paper and the top of form position.
- ⑦ Perform a printout self test.
- ⑧ Connect the unit to the host computer.
- ⑨ Start printing.

3. Attachments and mounting

A Removing the printer covers

- Lift the top cover in the direction of arrow (A) in the figure to remove.

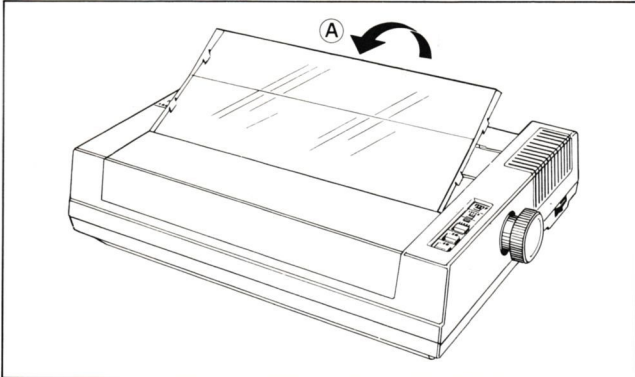

- Pull the front cover toward the front in the direction of arrow (B) in the figure until it will not go any further. Now lift up the front cover in the direction of arrow (C) in the figure to remove.

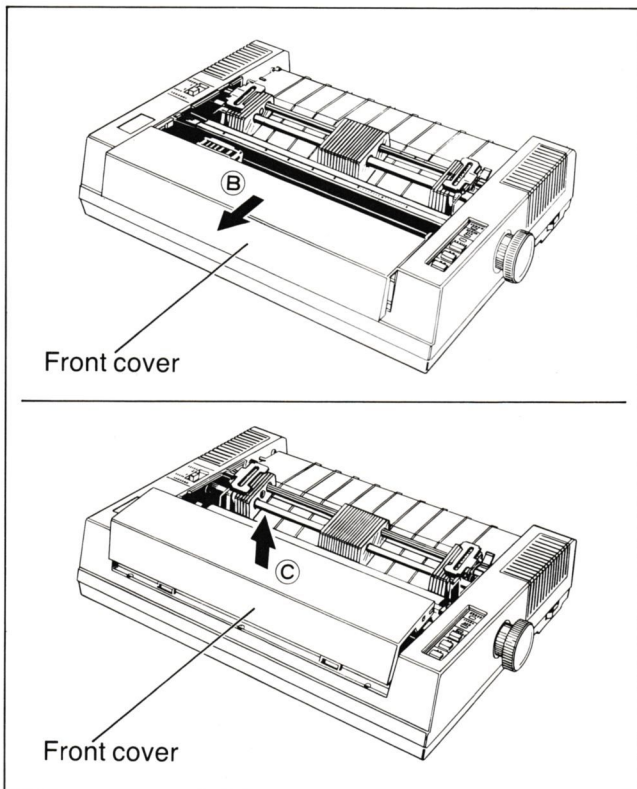

B Removing the carriage clamp

Remove the carriage clamp for preventing damage sustained during transportation, which secures the printing head section to the chassis. (Remove the red screw.)

When re-transporting the unit to another location, ensure that this clamp is used to secure the printing head section to the chassis.

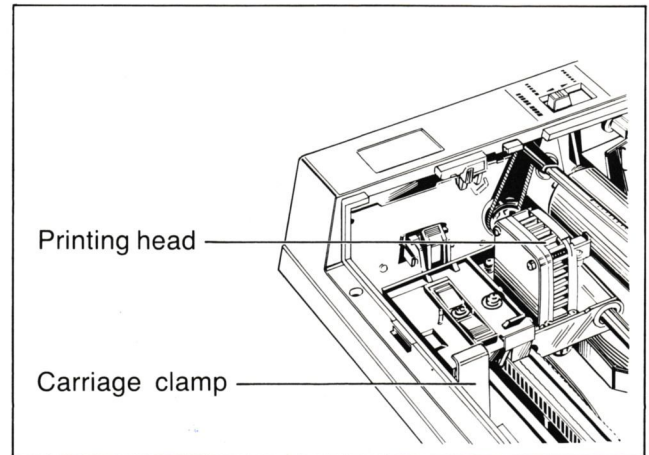

C Mounting the ribbon cassette

The accessory ribbon cassette should be mounted onto the printing head carriage as following method.

- (1) **Take hold of the carriage base of the printing head and move it slowly toward the center.**

(Under no circumstances should the printing head carriage be moved by holding the cassette holder.)

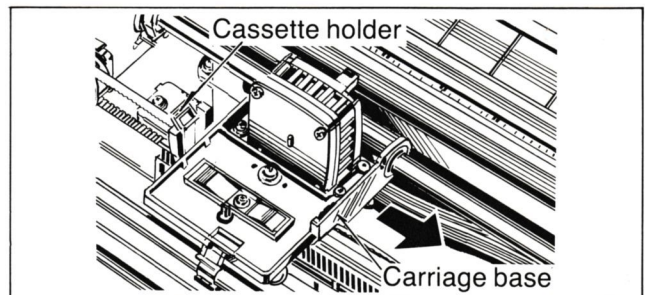

(2) Slack ribbon

Any ribbon slack should be eliminated by rotating the "knob" in the direction of the arrow (counter-clockwise).

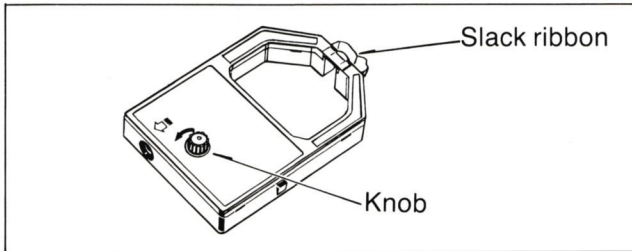

(3) Positioning onto the printing head carriage

Align the cassette such that the exposed ribbon at the cassette's end cutout fits between the platen and the nose of the printing head. Place the ribbon cassette on the printing head carriage.

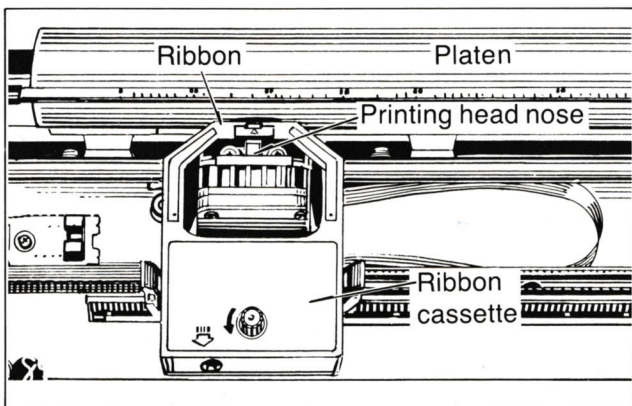

(4) Mounting onto the printing head carriage

Rotate the cassette's "knob" in the direction of the arrow (counter-clockwise) and push down on the cassette from above.

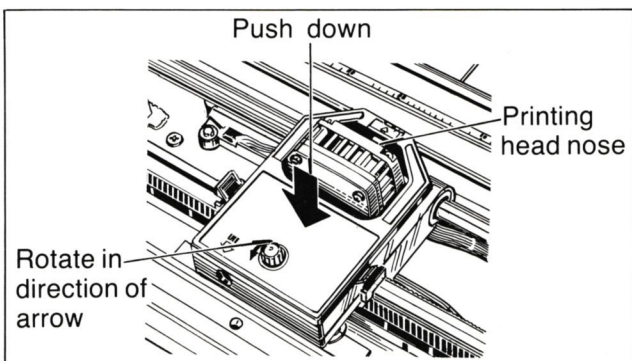

•By rotating the knob, the pin projecting from the carriage is engaged in the cassette's pin hole and the cassette holders on both sides of the carriage are fitted into place.

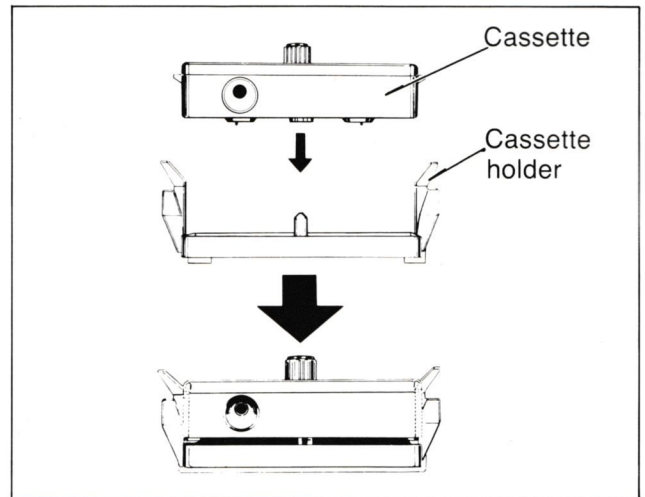

•When replacing the ribbon cassette, push the cassette holders in the direction of the arrow and take out the cassette.

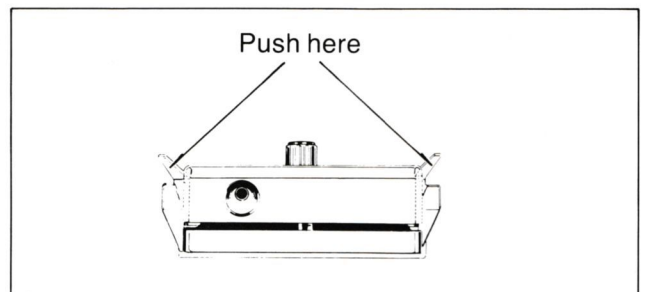

(5) Moving the printing head

After the ribbon cassette has been mounted, take hold of the carriage base and move it slowly toward the left (home position) until it will go no further.

D Connecting the power cord

Connect the plug on the power cord to the AC outlet.

E Mounting the paper separators

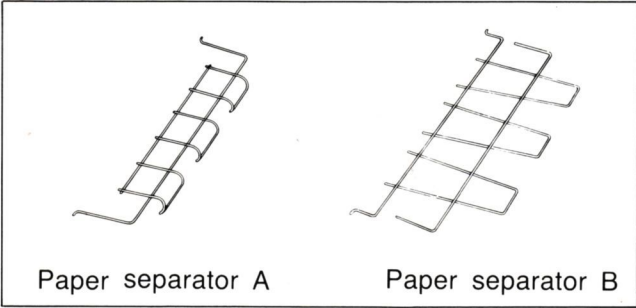

(1) Paper separator A
 Point the paper separator A in the direction shown in the figure and then mount it in the mounting holes.

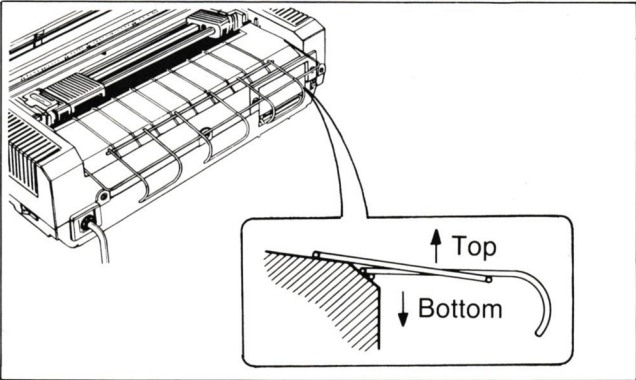

(2) Paper separator B
 Bend the paper separator B so that it curves upward as shown in the figure and mount it in the printer's mounting holes.

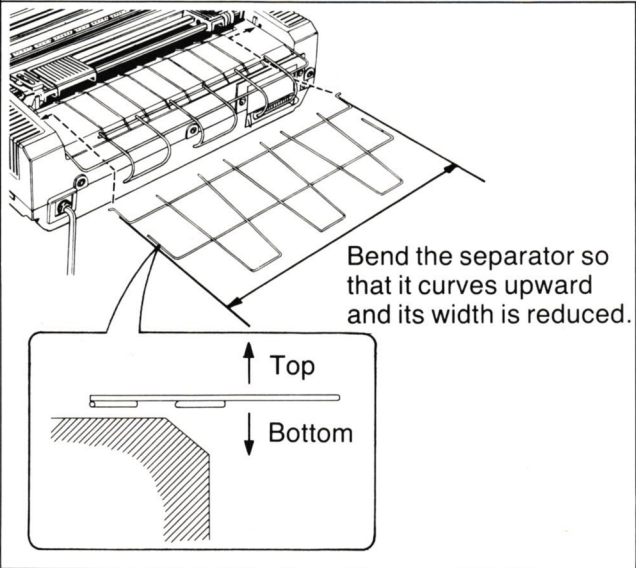

●When using letter paper
 Paper separators should be attached at all times, although they are not needed when using letter paper.

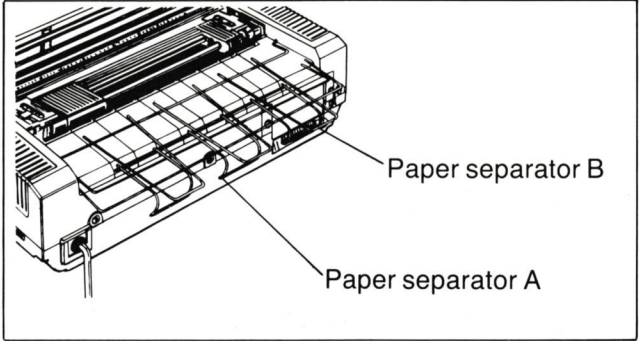

F Mounting the paper

(1) Power switch and paper feed selector

Inserting the paper is facilitated if the power switch is set to "on" first.

- ① The power switch is set to "on".
 - ② Set the paper feed selector lever to "friction".
- The clearance between the platen and roller below the platen is now stuck.

●If the paper is inserted, the paper is automatically drawn in as the platen rotates.

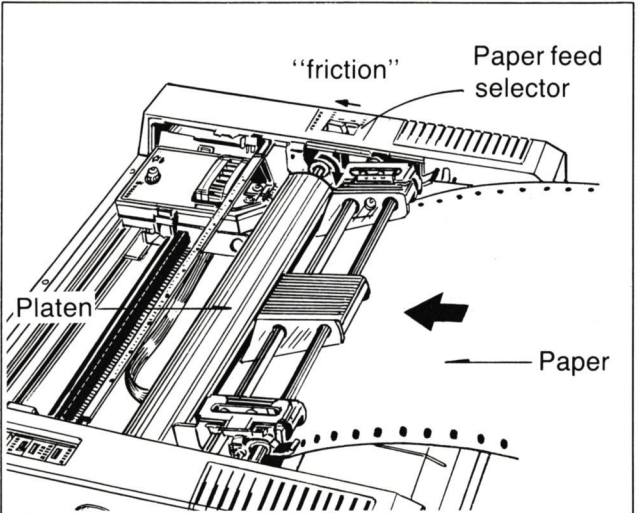

(2) Scale

Moves away the scale from the platen so that the paper does not come into contact with the scale when the top of the paper is fed out.

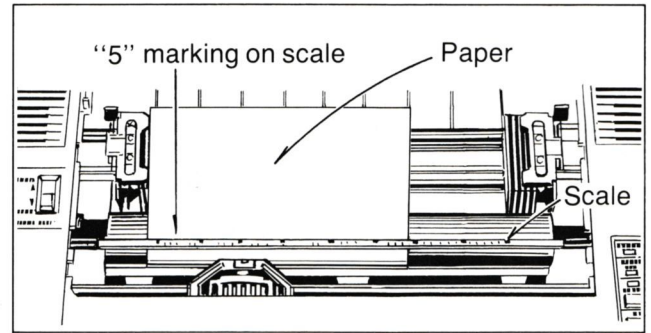
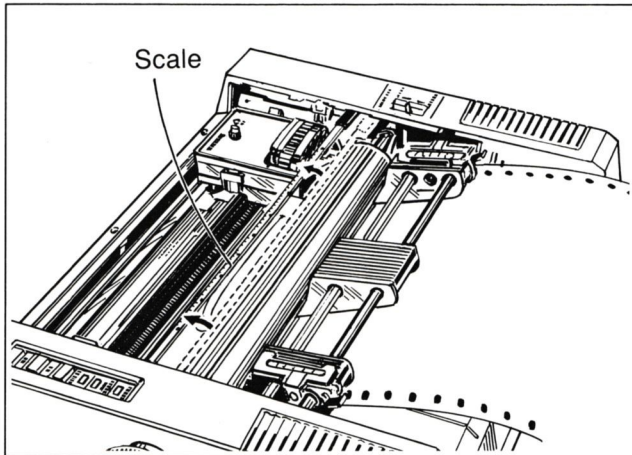

(C) Setting the temporary position of the tractors

Push the tractor clamping levers toward the rear and set the position.

(3) Setting the temporary position of the tractors

(A) Tractor clamping levers

Pull up the levers that clamp the left and right tractors.

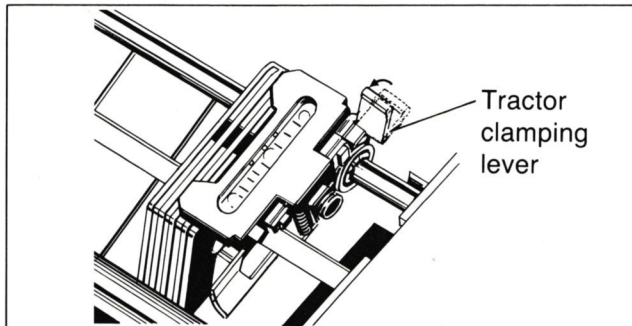

(B) Temporary position of tractors

The printing area is between "0" and "80" on the scale and so tractor position are set so that the printing area comes within the paper width.

(The first character is printed between "0" and "1" on the scale.)

(In order for the paper detector to detect when the paper has been inserted, the tractor position is set so that the left end of the paper comes on the left of the "5" marking on the scale.)

(4) Loading the paper

■ When using continuous paper

- Raise the paper separator B so that it stands vertically and push the paper in so that it is inserted underneath the paper separator B.

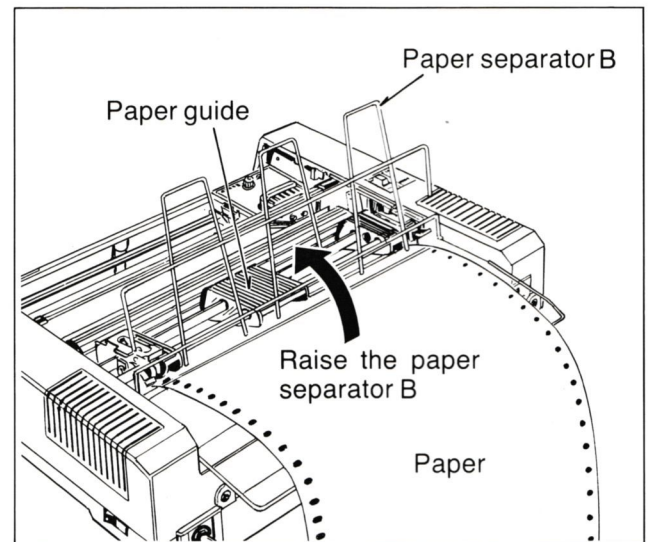

- The platen starts rotating automatically, the paper is wrapped around the platen and fed out.

(When the paper feed selector is set to "friction" side)

After the platen stops rotating, rotate the platen knob so that the paper is pulled out as shown in the figure.

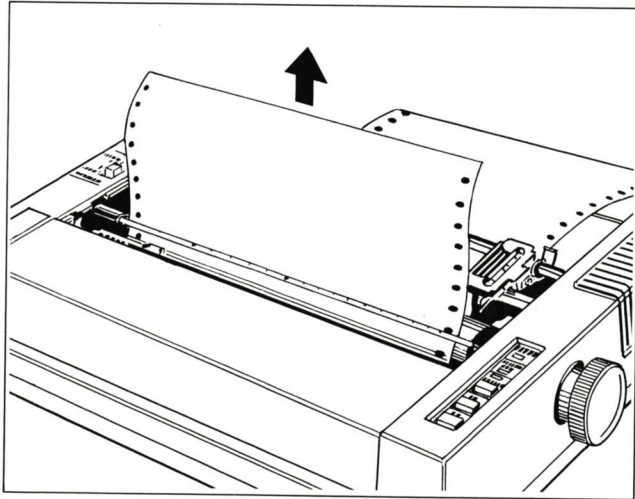

- When time is taken up by inserting the paper and the platen has stopped rotating: Pull out the paper (from the rear) and re-insert. Or set the paper feed selector to "tractor" and push in the paper. (If the paper feed switch is set to "tractor", the clearance between the platen and the roller underneath the platen is increased.)

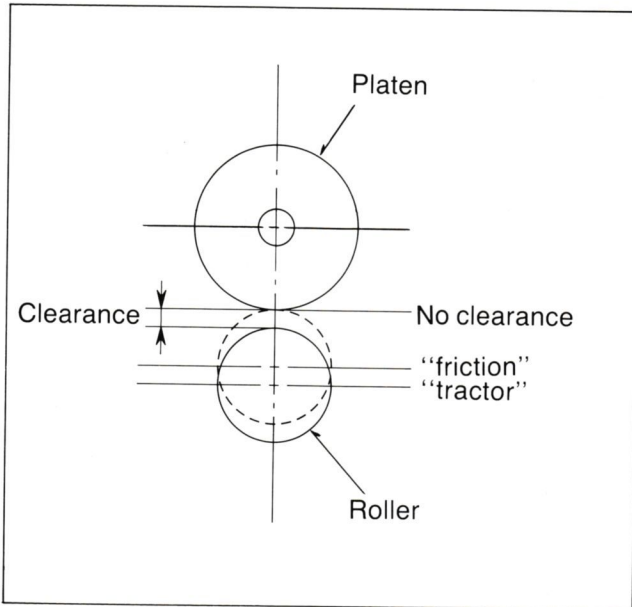

Note:

Paper will be set to the tractors without difficulty if paper feed selector is set to "tractor".

■ **When using letter paper**

Insert the paper between the paper guide and platen (as shown in the figure). The procedure after insertion is the same as the continuous paper.

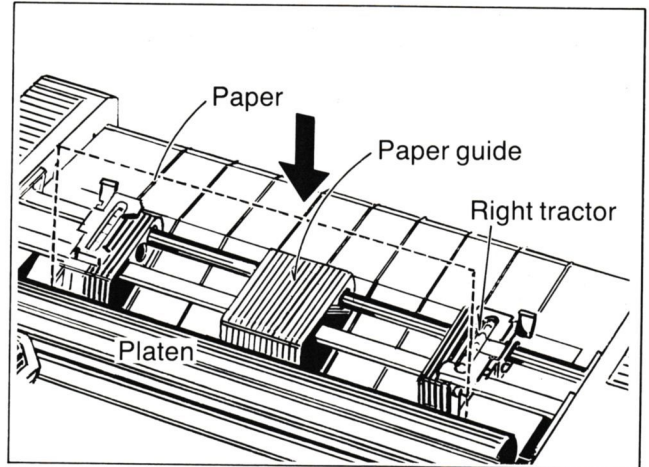

(5) Tractor covers

■ **When using continuous paper:**

- Open the tractor cover.

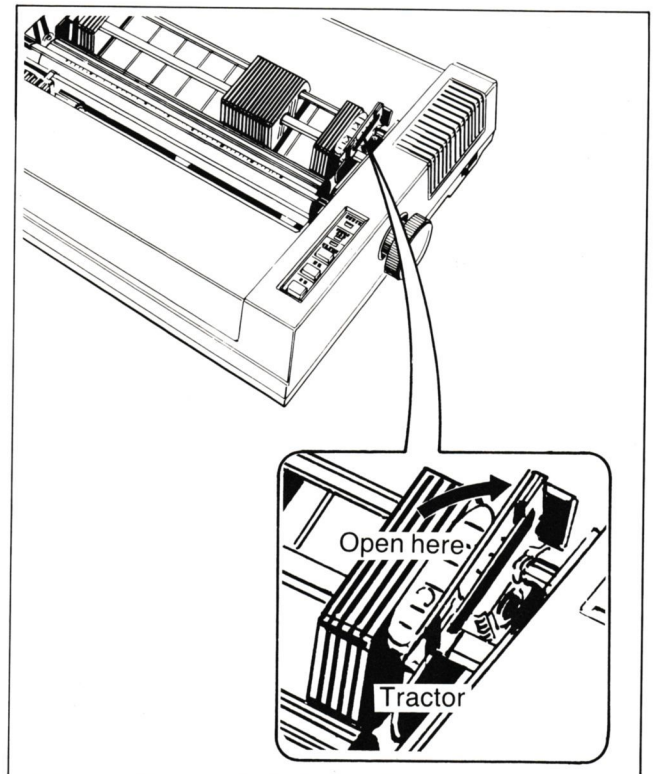

- Align the paper's sprocket holes in the paper which has been pulled out with the tractor pins and close the tractor cover.

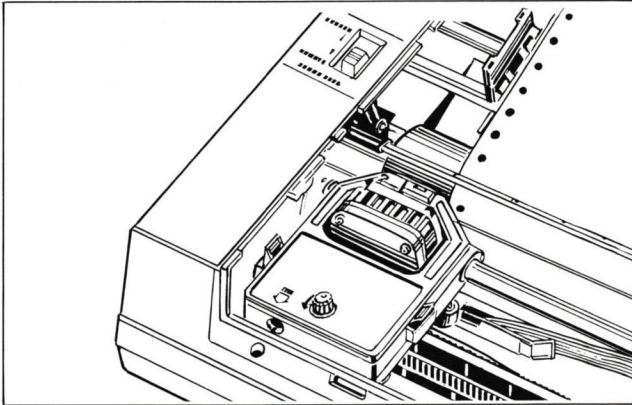

(6) Positioning the tractors

■ With continuous paper

As viewed from the front, adjust the position of the right tractor in accordance with the paper width and eliminate any slack in the horizontal direction.

- To move the tractor, pull up the tractor clamping lever and release the position. Now move the right tractor so that any slack in the horizontal direction is eliminated, then push down the clamping lever and clamp the position of the tractor.
- To eliminate slack in the paper's output direction, pull the paper gently from the paper insertion side.
- After having mounted the paper, bring the scale down on the platen.

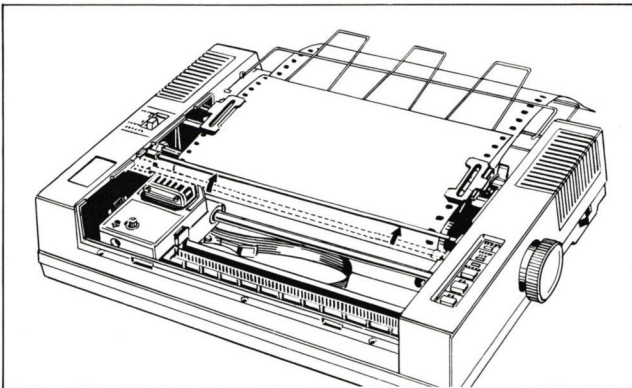

- Set the paper feed selector to "tractor" and perform a self-test or printing. (When using at the paper feed selector to "friction", it causes the paper to come off from the tractor pins.)

■ With letter paper

- Position the paper which has been pulled out so that it appears to be folded in two (see figure). Make sure that the ends are parallel and adjust the position of the right tractor according to the paper width.

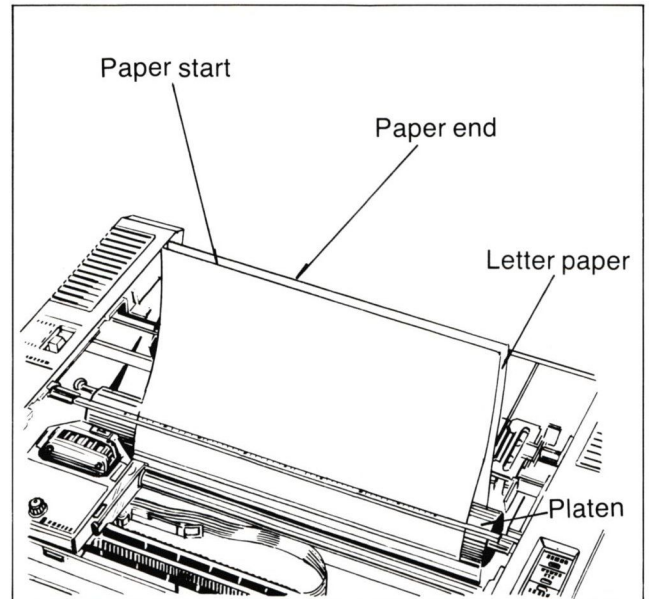

- To release the clamp, pull up the tractor clamping lever and adjust the position. After adjustment, push the tractor clamping lever down to secure.
- Set the paper feed selector to "friction" to maintain the paper.

The first character is printed between the "0" and "1" markings on the scale.

*When replacing continuous paper

- When the continuous paper is replaced, the number of lines left on the page is memorized by the CPU and so it is recommended that the form feed switch (F.F.) is pushed and the line count is cleared.
- Return the paper separator B to its original position.

G Adjusting the distance between the printing head and platen

Head gap lever (orange-colored)

According to the thickness of the paper, move the head gap lever and adjust the distance between the printing head and platen.

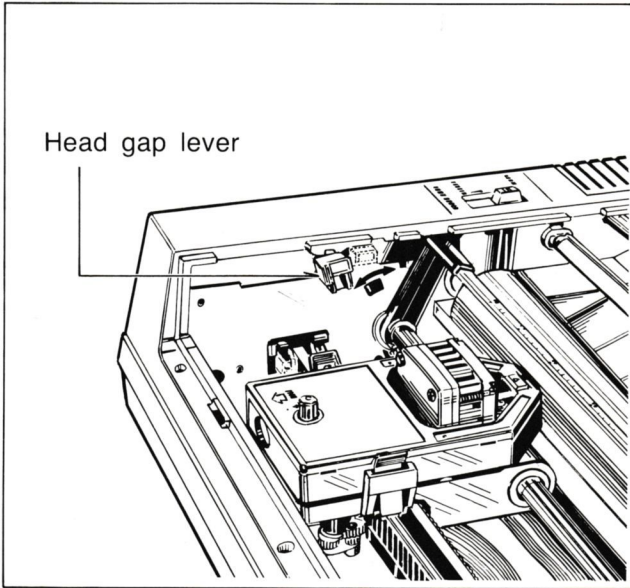

With 1 sheet: Push the lever to the platen side.
With 2 or 3 sheets: Pull the lever to the front side. (or with equivalent to 2 or 3 sheets)

- When the number of sheets and the setting position for the same number of sheets do not coincide, an increased shock results, the service life of the printing head is shortened and malfunctions may occur. This check should therefore be made.

Note:

When the printing head pin catches on the ribbon or the printing starts to fade during a printing operation, the head pin will wear. In cases like this, ask your dealer to replace with a new head.

H Installing the paper

In cases where the printer is used on a desk with Z-fold paper, as in the figure, the paper can be folded accordion style.

Make sure that the top surface of the Z-fold paper is not higher than the paper separators; If not, the paper will not be fed properly.

Set the Z-fold paper parallel to both the printer and the printing operation section.

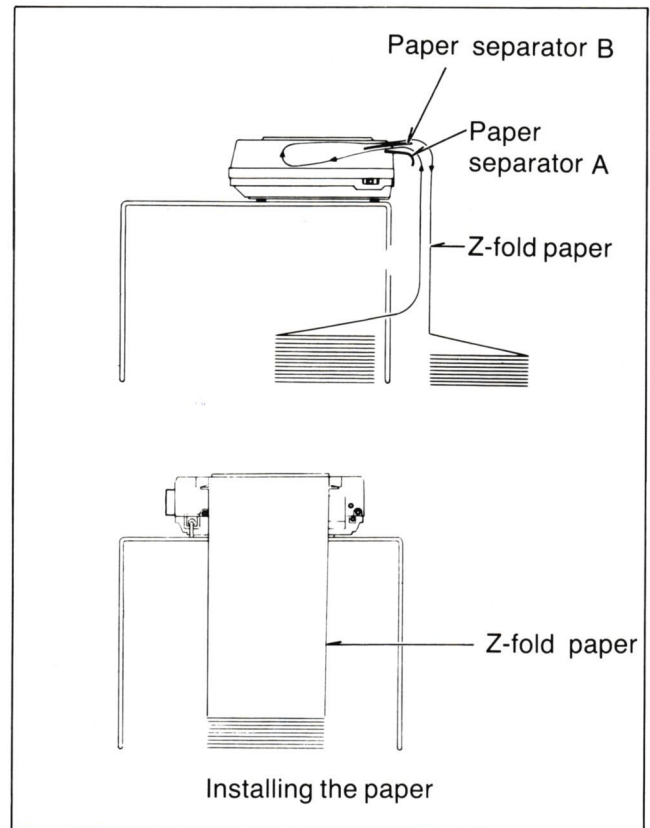

■ Removing the paper

After printing, set the paper feed selector to the friction side and rotate the knob to take out the paper, or set the paper feed selector to "tractor" and draw out the paper from the rear.

*With continuous paper

Once the next machine perforation has reached paper separator B, tear along the perforations by hand.

I Fitting the covers into position

(1) Front cover

First, insert the front cover in the direction ①, with respect to the printer, as shown in the figure.

Then push it in the direction ② to fit the cover into place.

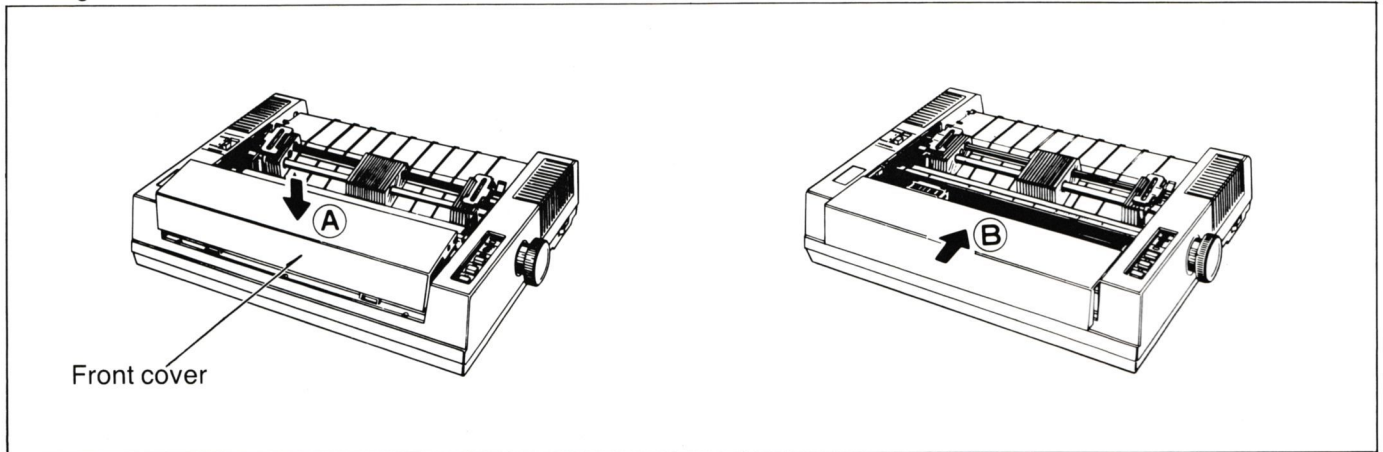

(2) Top cover

Insert the top cover in the direction of the arrow such that two tabs on its side fit into the main unit's cutouts.

Caution:

Do not operate the unit unless both covers have been mounted.

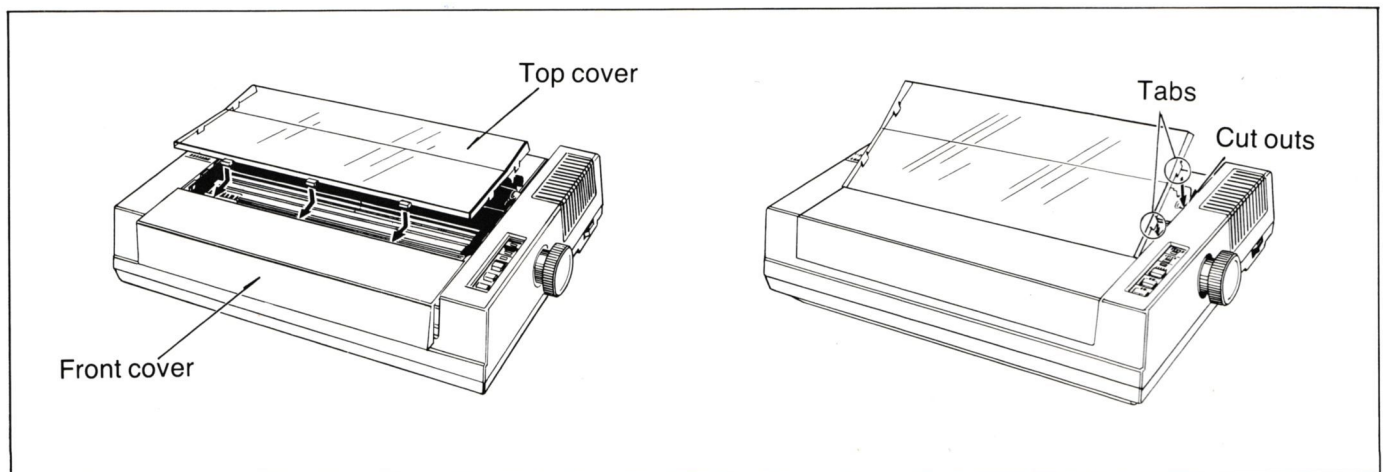

J Aligning the top of form position

Knob

Rotate the knob and set the position of the paper for printing at the desired position on the paper.

Note:

When the power is switched to "off", the knob rotates lightly.

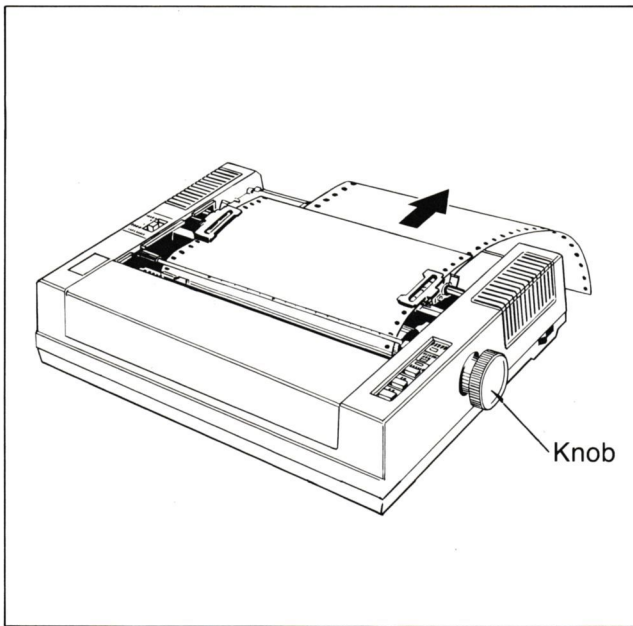

The first character is printed between the "0" and "1" markings on the scale.

- Return paper separator B to its original position.

*Setting the top of printing position of Z-fold paper

Adjusting the machine perforation of Z-fold paper to the upper end of scale, the characters are printed on the 5th line under the machine perforations.

(Refer to figure.)

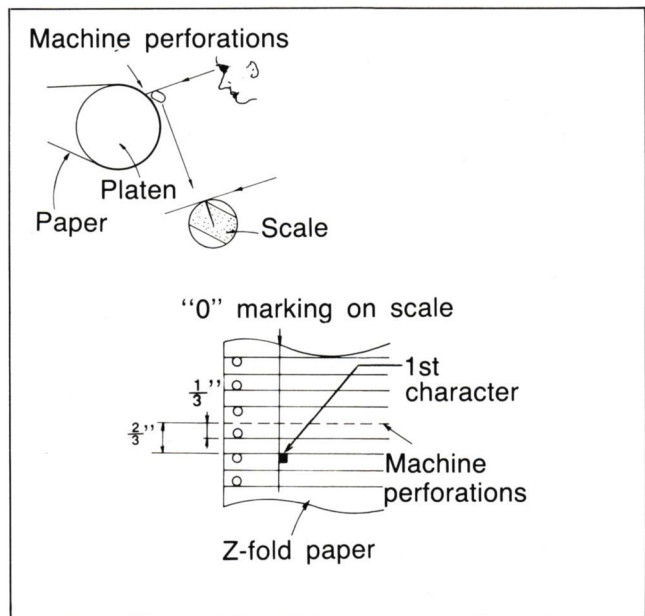

*Setting the top of printing position of short letter paper

Adjusting the paper start to the upper end of scale, the paper is kept horizontally and the characters are printed under 2/3 inch from the paper start. (Refer to figure.)

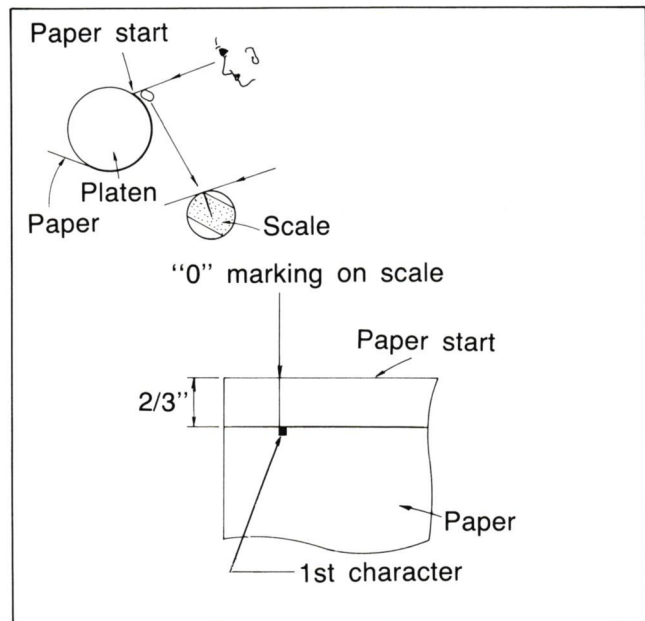

*When replacing continuous paper

- When the continuous paper is replaced, the number of lines left on the page is memorized by the CPU and so it is recommended that the form feed switch (F.F.) is pushed and the line count is cleared.

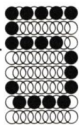

FUNCTIONS

1. Switches

A. Power switch

This switch serves to turn the power on and off. When the power is switched on, the power indicator lights. If the paper is loaded and then the power is switched on, the unit will be connected on-line.

If the paper is not loaded and then the power is switched on, the buzzer sounds once and the units is connected off-line.

B. On-line switch

By depressing this switch, selection between the host computer and printer can be made on-line or off-line.

■ When the on-line switch is pressed in the off-line mode:

[When the paper has been set]

- The on-line switch indicator lights up green.
- The on-line (select) status is established.
- The \overline{ACK} signal is output from the printer.
- The on-line switch is operational (the other switches are non-operational).

[When the paper has not been set (while the out of paper indicator is lighted)]

- The out of paper indicator lights.
- The on-line switch is non-operational.
(The other switches are operational.)

■ When the on-line switch is pressed in the on-line mode:

- The on-line switch indicator (green) goes off.
- The off-line (de-select) status is established.
- The \overline{ACK} signal from the printer is not output.
- All the switches are made operational.

Use of the on-line switch should be kept to a minimum.

Use this switch only when off-line operations are necessary and ensure that it is "on" when a remote device control.

C. Form feed switch

Pressing this switch enables feeding of the paper to the next top of form position. Pressing it again has the effect of feeding the paper in page units.

D. Line feed switch

Every time this switch is pressed, the paper is fed by one line.

2. Self test printing

Self test printing results when the power is switched on while line feed switch is depressed.

- Self test printing involves first the printout of all the font characters contained inside repeatedly for 3 times and then the printout of 95 ASCII characters repeatedly.
- Set the power switch to "off" to stop the self test printing operation.
- Self test printing also stops when the paper runs out.

3. Indicators

A. Power indicator

This lights when the power switch is "on" and goes off when it is at "off".

B. On-line indicator

This lights in the on-line (select) mode and goes off in the off-line (de-select) mode.

C. Out of paper indicator

This lights when only 7 lines [7/6 inches (29.6 mm)] remain on the paper and the printing stops. The buzzer will sound and the off-line status is established. The \overline{ACK} signal is not transmitted.

Press the on-line switch again after the paper has been replaced to re-establish the on-line mode and continue printing from the start of the line.

4. Out-of-paper detector and other functions

A. Out of paper detector

The detector contained near the paper insert slot detects that the printer is out of paper (only 7 lines remaining) and it causes the out of paper indicator to light.

- When paper with a narrow width is being used, the tractor position is set so that the left end of the paper comes on the left of the "5" marking on the scale, the out of paper detection function can be activated.
- When the detector detects "out of paper", the CPU sounds the buzzer, printing stops, and off-line status is established.

B. Buzzer

Housed inside the case and the buzzer sounds for 0.5 second in the following circumstances.

(1) At out of paper

When there is no more paper, the printing stops and the buzzer sounds once simultaneously.

(2) With overloading

When, for instance, the operation of the printing head is made stiff by foreign matter inside the unit and this results in an overload. At that time the buzzer activates continuously with 0.5 second-sounding and 0.5 second-silence.

(3) When the BELL code has been received

C. Printing head temperature protection

■ Continuous printing

When printing underlines, semi graphic or bit images continuously, bear the following points in mind in order to prevent the temperature of the printing head from rising.

- Keep continuous usage of the same pin to within 1 line (1152 dots).
- When continuous usage of the same pin spans more than 1 line, stop time should be provided by external operations between printouts. A stop time which is double the length of the printing time must be provided after a printout (1 line).

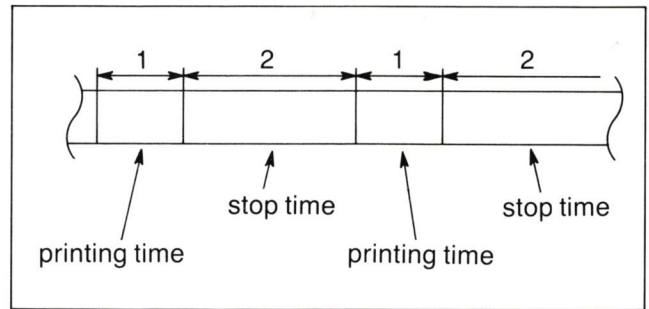

5. Initial mode and DIP switch

A. Initialization

- (1) When the AC power is switched off and then switched back on.
- (2) When the PRIME signal has been received.
- (3) When the printer reset command "`[ESC] + [@]`" has been received.
 - When initialization is performed, the printer mode (initial mode) is set as follows.
 1. The printing head returns to the home position (at the far left).
 2. The on-line status is established provided that paper is inserted.
 3. The print buffer is cleared (the previous data memory is lost).
 4. All the vertical tab settings are cleared.
 5. Printing is set up with ordinary characters and pica pitch.
 6. The horizontal default tabs are set every 8 columns.
 7. The print font is not italic but normal.
 8. The paper feed of 1 line is set to 1/6" (4.2 mm).
 9. The international character selection is set to ENGLAND oriented characters.
 10. The code is set to the 8-bit code.
 11. AUTO FEED XT signal is not fixed internally.
 12. The skip perforation operation [1 inch (25.4 mm) is skipped] is not performed.
 13. The length of 1 page is set to 11" (279.4 mm) and the line position is designated as the top of form position.
 - The printer modes 5, 8, 9, 10, 11, 12 above are established in accordance with the setting of the DIP switch.

B. DIP switch

An easily accessible DIP switch is provided to be used by the operator to change the operation mode.

■ DIP switch setting Procedure:

Carefully raise the right side of the unit until it is vertical and resting on the left side. The DIP switch will be visible through a rectangular opening in the rear center of the machine bottom. Support the unit while setting the switches to the desired positions.

Note: "ON" is toward the rear.

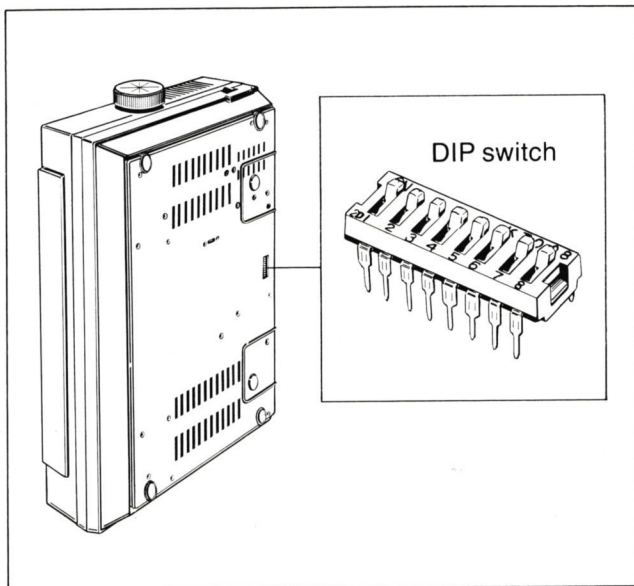

DIP switch functions and setting

No.	Function	OFF	ON	Position when unit shipped
1	Selection of printing mode	Elite	Pica	ON
2	Selection of skip perforation or not	Skip	No skip	ON
3	AUTO FEED XT signal	No line feed (Not fixed internally)	Line feed (Fixed at low internally)	OFF
4	7-bit/8-bit code selection	8-bit	7-bit	OFF
5	International character selection (ENGLAND characters selected when unit shipped)	See DIP switch setting table		ON
6				OFF
7				OFF
8	1-line paper feed selection	1/6" (4.2 mm)	1/8" (3.2 mm)	OFF

DIP switch setting

SW-5	SW-6	SW-7	International characters
ON	ON	ON	U.S.A.
ON	ON	OFF	FRANCE
ON	OFF	ON	GERMANY
ON	OFF	OFF	ENGLAND
OFF	ON	ON	DENMARK
OFF	ON	OFF	SWEDEN
OFF	OFF	ON	ITALY
OFF	OFF	OFF	SPAIN

C. Modes

•Skip perforation

By using the skip operation, it is possible to prevent any characters from being printed over the machine perforations on the paper. For instance, the paper can be set using the skip perforation operation (if 6 lines are skipped) so that no characters are printed for 3 lines on either side of the perforations (6 lines in all).

(Example)

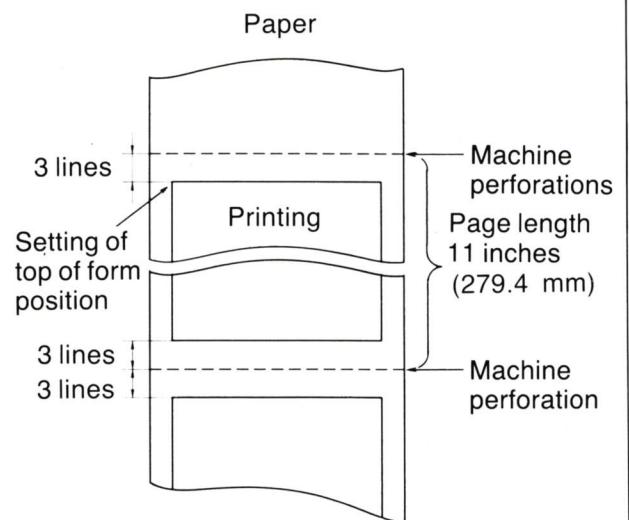

Blanks which are useful for keeping lists, are provided between pages.

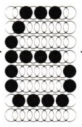

INTERFACE

This printer is provided with a parallel interface which is composed of an 8-bit TTL based on Centronics specifications.

- **Data transfer speed:** 1000 cps (Min)
- **Sync system:** Synchronization with externally supplied \overline{STB} (strobe) pulse
- **Handshake:** Processing is done with the $BUSY/\overline{ACK}$ signal. When the $BUSY$ signal is high, the printer does not acknowledge the external signal because the printer is in operation. When the data input is completed, the \overline{ACK} =low signal is output and then the external signal is accepted.

1. Connector

Plug: 57-30360 (AMPHENOL) or equivalent
Use the plug above for connection with this printer.

2. Connector pin configuration

Signal pin	Return side pin	Signal	Direction
1	19	\overline{STB}	Input
2	20	DATA 1	Input
3	21	DATA 2	
4	22	DATA 3	
5	23	DATA 4	
6	24	DATA 5	
7	25	DATA 6	
8	26	DATA 7	
9	27	DATA 8	
10	28	\overline{ACK}	Output
11	29	$BUSY$	Output
12		PE	Output
13		SLCT	Output
14		$\overline{AUTO FEED XT}$	Input
15			
16		SG	
17		FG	
18		+5 V	Output
31	30	\overline{PRIME}	Input
32		\overline{ERROR}	Output
33		SG	
34			
35			
36			

Note 1: Direction

“Input” denotes the flow of the signals entering the printer while “output” denotes the signals output from the printer.

Note 2: Return side

This denotes twisted pair return which is connected to the signal ground level.

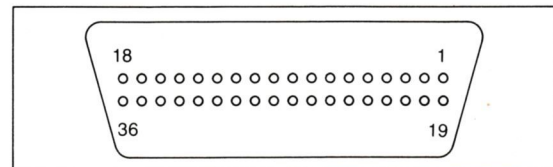

Note 3: The interface conditions are based on the TTL level, and the signal rise and fall time is less than 0.2 μ sec.

Note 4: The transfer of data to the printer is executed according to the level of the $\overline{\text{ACK}}$ signal or $\overline{\text{BUSY}}$ signal.

(Data can be transferred to the printer when the $\overline{\text{BUSY}}$ signal is low or when the host computer accepts the $\overline{\text{ACK}}$ signal.)

Note 5: The input/output buffer circuit conforms to the specifications below.

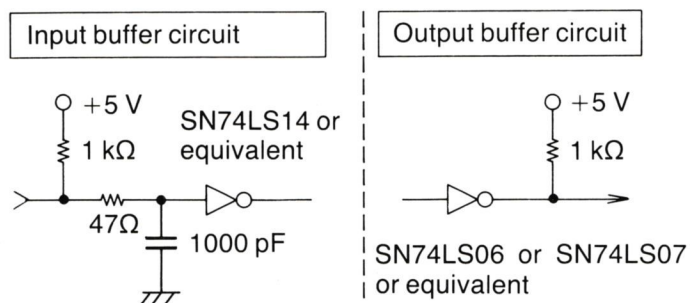

3. Connector pin signals

A $\overline{\text{STB}}$STROBE

- Strobe signal for reading in data signals (DATA 1–DATA 8)
- Negative logic signal
Normal status (no signal)=high,
signal present=low
- Pulse width must be more than 0.5 μ sec at receiving terminal.
- When $\overline{\text{PE}}$ =low (not out of paper status), only DC1 code is acknowledged even when $\overline{\text{SLCT}}$ =low (off-line), $\overline{\text{ERROR}}$ =low and $\overline{\text{BUSY}}$ =high.
- $\overline{\text{STB}}$ signal for sending code data or image data to printer must not be input into printer while $\overline{\text{BUSY}}$ =high in on-line mode.
- $\overline{\text{STB}}$ signal for sending code data or image data to printer must not be input into printer until $\overline{\text{ACK}}$ signal is returned to computer in on-line mode.

B DATA 1-DATA 8

- These input signals of various pins indicate information from parallel data composed of bit 1 through bit 8.
DATA 8: MSB (most significant bit)
- Positive logic signals
Signal present=high, no signal=low
- Signals are read in synchronization with $\overline{\text{STB}}$ signal.
- Status of each data bit must be valid 0.5 μ sec before the following edge of $\overline{\text{STB}}$ signal and it must be held for a period of 0.5 μ sec after the rising edge.

C $\overline{\text{ACK}}$ACKNOWLEDGE

- This is the response signal for the $\overline{\text{STB}}$ signal. It is an acknowledgement pulse with a width of about 3 μ sec. It is output from the printer when the $\overline{\text{BUSY}}$ signal goes from high to low or when the data input is completed.
 - Negative logic signal
 - $\overline{\text{BUSY}}$ =high is established and $\overline{\text{ACK}}$ signal is not returned when the DC3 (DSL T) code is input.
 - The $\overline{\text{STB}}$ signal is ignored during the time until $\overline{\text{ACK}}$ signal is returned or $\overline{\text{BUSY}}$ =low is established.
 - In the following circumstances $\overline{\text{ACK}}$ signal is output even without the $\overline{\text{STB}}$ signal having been received.
 - (1) When the power is switched on with the paper having been set and the on-line mode is established.
 - (2) When the $\overline{\text{PRIME}}$ signal is received in the off-line mode and the on-line mode is established.
 - (3) When the printer reset command "[ESC]+[@]" is received.
 - (4) When the on-line switch is pressed in the off-line mode and the on-line mode is established.
 - (5) When the DC1 (SLCT) code is received in the off-line mode and the on-line mode is established.
- [Initialization is performed with (1), (2) and (3)]

D BUSY

- This indicates whether or not the printer is operating. When high, the busy status is indicated; when low, the data input is received and acknowledged.
- A high-level signal of BUSY is output and data are not acknowledged during data acceptance, printing, occurrence of errors, function operations (during paper feed operations with the command) and in the off-line mode.
- Only the DC1 (SLCT) code is acknowledged in the off-line mode.

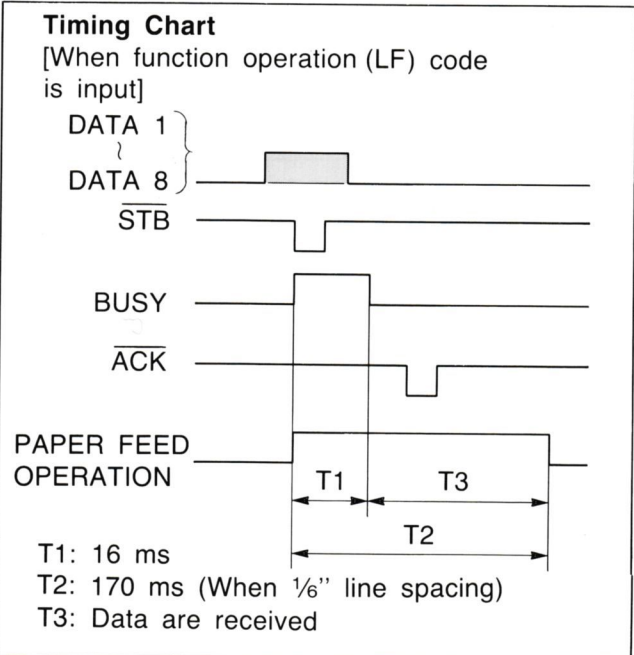
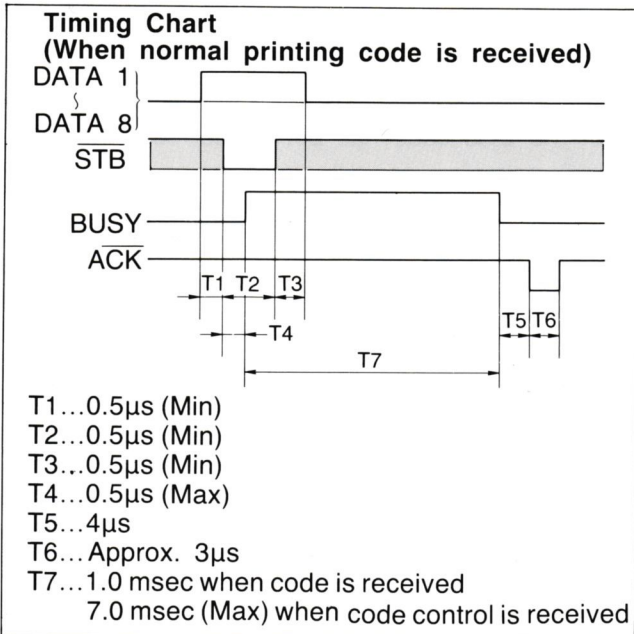

E PE.....PAPER END

- This signal indicates that there are 7 lines of paper left. It is low when the paper has been normally loaded and when only 7 lines remain, a high-level signal is output.
- When printing continues and only 7 lines are left, this output signal is set high, the off-line mode is established and the printing is stopped.

In other words:

PE = High
 ERROR = Low... Out of paper indicator lights and buzzer sounds for about 0.5 sec.

SLCT = Low

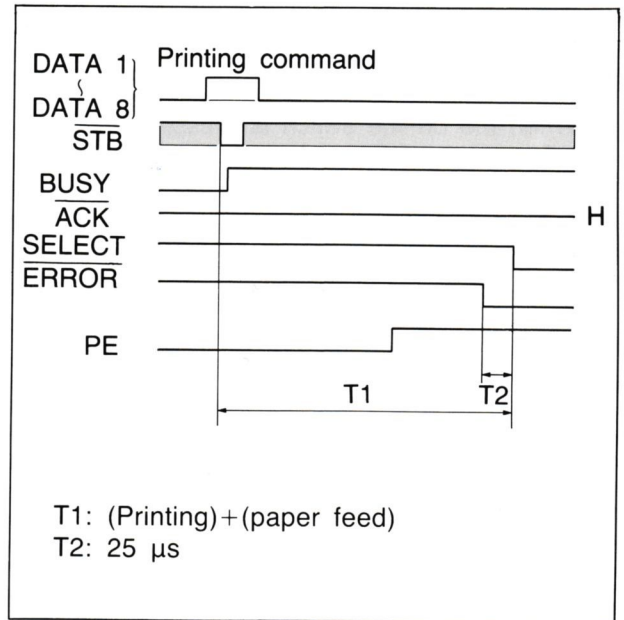

- Once the paper is installed, the out of paper indicator goes out first. PE goes low although the mode is still off-line. The on-line mode is established and ACK signal is transmitted if either the on-line switch is pressed or the DC1 (SLCT) code is received.
- If the off-line mode is effective and continuous paper has not been loaded, the on-line switch and DC1 (SLCT) code are non-operational.

F SLCT...SELECT

- This output signal indicates the select (on-line) mode when high and the de-select (off-line) mode when low.
- In order to establish the select (on-line) mode, one of the operations below is performed and then the $\overline{\text{ACK}}$ signal is output.

When, with the paper already set:

- (1) The power is switched on.
 - (2) The $\overline{\text{PRIME}}$ signal is received.
 - (3) “[ESC]+[@]” command is received.
 - (4) The on-line switch is pressed in the off-line mode.
 - (5) The DC 1 (SLCT) code has been received in the off-line mode.
- [Initialization is performed with (1), (2) and (3).]

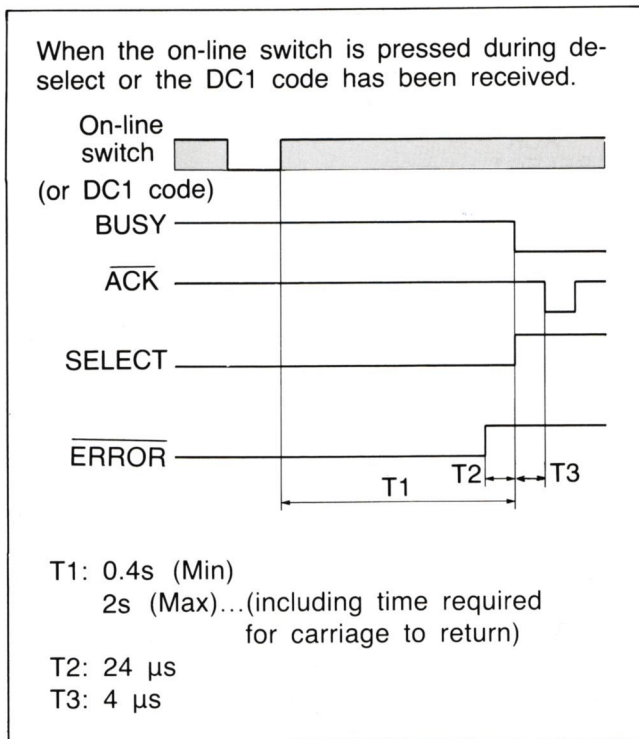

- In order to establish the de-select (off-line) mode, one of the operations below is performed. Then the $\overline{\text{ACK}}$ signal is not output.

When, with the paper not set:

- (1) The power is switched on.
 - (2) The $\overline{\text{PRIME}}$ code has been received.
 - (3) “[ESC]+[@]” command is received.
 - (4) The on-line switch is pressed in the on-line mode.
 - (5) The DC 3 (DSLCT) code has been received in the on-line mode.
- [Initialization is performed with (1), (2) and (3)]

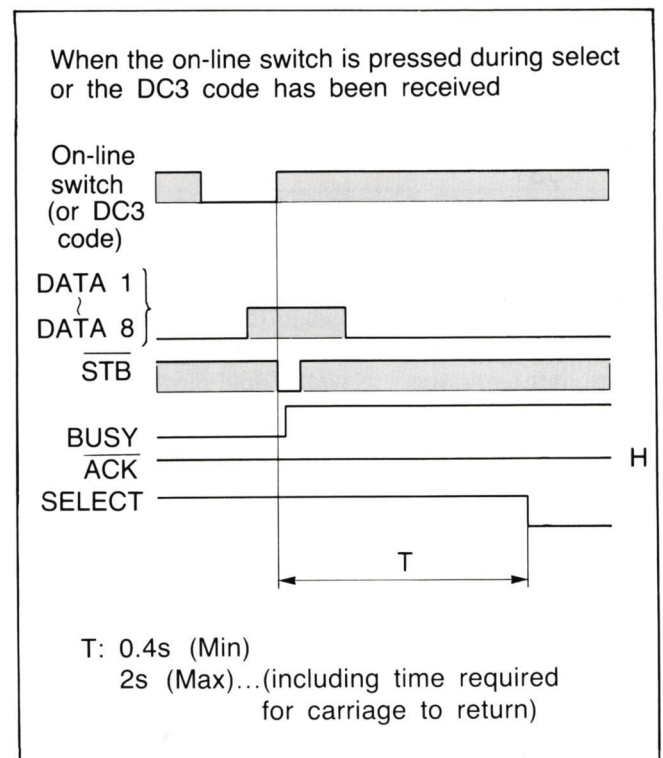

G AUTO FEED XT

- This signal designates whether or not a new line is made after the printing is executed by the reception of CR code. This is a negative logic signal.
- When $\overline{\text{AUTO FEED XT}}$ signal is set high, a new line is not made.
When $\overline{\text{AUTO FEED XT}}$ signal is set low, a new line is made.
- This signal can be fixed at low level by DIP switch NO.3.

H SG.....SIGNAL GROUND

- Logic ground level.

I FG.....FRAME GROUND

- Printer chassis GND level.
- Printer chassis GND level is separate from logic GND level.

J +5 V

- This is the power supply pin for evaluation. Do not use as the power supply pin for external equipment.

K PRIME

- This input signal initializes the printer.
- Negative logic signal
Signal present=low, no signal=high. The initialization is performed at the point when the level is changed from low to high.
- The signal can be received during all printer operations. Once the $\overline{\text{PRIME}}$ signal is received, operation is suspended.
- The printer is set as follows by initialization.
 - (a) The data stored in the print buffer and the functions set by the ESC code are cleared.
 - (b) The printing head returns to the home position (far left).
 - (c) The length of the page is made 11 inches (279.4 mm).
 - (d) The length of paper feed is set to $\frac{1}{8}$ inch (4.2 mm).
 - (e) The horizontal default tabs are set every 8 columns.
 - (f) The expansion function designation is released and operation proceeds in accordance with initial mode.
(Ordinary characters are printed in pica pitch. The $\overline{\text{AUTO FEED XT}}$ signal is not fixed internally and the skip perforation operation is not conducted).
- When the paper is set and this signal is received in the off-line mode, the printer is initialized and set to the on-line mode.

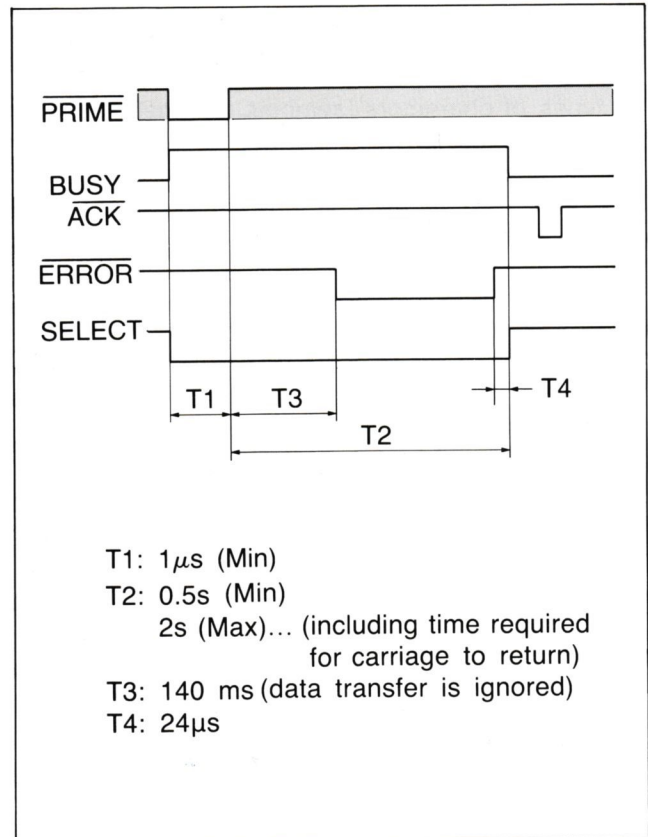

L ERROR

- This output signal indicates whether or not the printer is at the error status.
- Negative logic signal
Error status=low; normal status=high
 $\overline{\text{ERROR}}$ =low in off-line mode as well.
- When an error is produced:
The buzzer activates continuously with 0.5 second-sounding and 0.5 second-silence. (overload)
- The following situation results in the error status:
Overload of the head carriage.
- To release the overload status, turn off the power switch and then turn it on after the overload has been repaired.

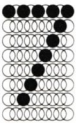

CONTROL CODE

1. Code tables and printing samples

The types of characters, symbols, numbers and semi graphics sent to the printer are given below together with printing samples.

A Code table

① Code table (8-bit)

High-order bits Low-order bits				b8	0	0	0	0	0	0	0	0	1	1	1	1	1	1	1	1		
				b7	0	0	0	0	1	1	1	1	0	0	0	0	1	1	1	1		
				b6	0	0	1	1	0	0	1	1	0	0	1	1	0	0	1	1		
				b5	0	1	0	1	0	1	0	1	0	1	0	1	0	1	0	1		
b4	b3	b2	b1		0	1	2	3	4	5	6	7	8	9	A	B	C	D	E	F		
0	0	0	0	0	NULL		SP	0	@	§	P	'	p		SP	0	@	P	'	p		
0	0	0	1	1		DC1	!	1	A	Q	a	q	£	DC1	!	1	A	Q	a	q		
0	0	1	0	2		DC2	"	2	B	R	b	r	..	DC2	"	2	B	R	b	r		
0	0	1	1	3		DC3	#	3	C	S	c	s	,	DC3	#	3	C	S	c	s		
0	1	0	0	4		DC4	\$	4	D	T	d	t	,	DC4	\$	4	D	T	d	t		
0	1	0	1	5			%	5	E	U	e	u	§	⌋	%	5	E	U	e	u		
0	1	1	0	6			&	6	F	V	f	v	┌	└	&	6	F	V	f	v		
0	1	1	1	7	BEL		'	7	G	W	g	w	BEL	┘	'	7	G	W	g	w		
1	0	0	0	8	BS		(8	H	X	h	x	BS	┘	(8	H	X	h	x		
1	0	0	1	9	HT)	9	I	Y	i	y	HT	┘)	9	I	Y	i	y		
1	0	1	0	A	LF		*	:	J	Z	j	z	LF	┘	*	:	J	Z	j	z		
1	0	1	1	B	VT	ESC	+	;	K	[Ä	k	{	ä	VT	ESC	+	;	K	/	k	{
1	1	0	0	C	FF		,	<	L	\	ö	l		ö	FF		,	<	L	\	/	/
1	1	0	1	D	CR		-	=	M]	ü	m	}	ü	CR	-	-	=	M	/	m	}
1	1	1	0	E	SO		.	>	N	^	n	~	ß	SO	┘	.	>	N	^	n	~	
1	1	1	1	F	SI		/	?	O	_	o	DEL	SI	┘	/	?	O	_	o	DEL		

② Code table (7-bit)

High-order bits Low-order bits				b8	0	0	0	0	0	0	0	0	1	1	1	1	1	1	1	1				
				b7	0	0	0	0	1	1	1	1	0	0	0	0	1	1	1	1	1	1		
				b6	0	0	1	1	0	0	1	1	0	0	1	1	0	0	1	1	0	0	1	1
				b5	0	1	0	1	0	1	0	1	0	1	0	1	0	1	0	1	0	1	0	1
b4	b3	b2	b1		0	1	2	3	4	5	6	7	8	9	A	B	C	D	E	F				
0	0	0	0	0	NULL		SP	0	@	P	'	p	NULL		SP	0	@	P	'	p				
0	0	0	1	1		DC1	!	1	A	Q	a	q		DC1	!	1	A	Q	a	q				
0	0	1	0	2		DC2	"	2	B	R	b	r		DC2	"	2	B	R	b	r				
0	0	1	1	3		DC3	#	3	C	S	c	s		DC3	#	3	C	S	c	s				
0	1	0	0	4		DC4	\$	4	D	T	d	t		DC4	\$	4	D	T	d	t				
0	1	0	1	5			%	5	E	U	e	u			%	5	E	U	e	u				
0	1	1	0	6			&	6	F	V	f	v			&	6	F	V	f	v				
0	1	1	1	7	BEL		'	7	G	W	g	w	BEL		'	7	G	W	g	w				
1	0	0	0	8	BS		(8	H	X	h	x	BS		(8	H	X	h	x				
1	0	0	1	9	HT)	9	I	Y	i	y	HT)	9	I	Y	i	y				
1	0	1	0	A	LF		*	:	J	Z	j	z	LF		*	:	J	Z	j	z				
1	0	1	1	B	VT	ESC	+	;	K	[k	{	VT	ESC	+	;	K	[k	{				
1	1	0	0	C	FF		,	<	L	\	l		FF		,	<	L	\	l					
1	1	0	1	D	CR		-	=	M]	m	}	CR		-	=	M]	m	}				
1	1	1	0	E	SO		.	>	N	^	n	~	SO		.	>	N	^	n	~				
1	1	1	1	F	SI		/	?	O	_	o	DEL	SI		/	?	O	_	o	DEL				

B Printing samples

(1) Ordinary characters with pica pitch

```
!"#$%&'()*+,-./0123456789:;<=>?@ABCDEFGHIJKLMNPOQRSTUVWXYZC  
\J^_`abcdefghijklmnopqrstuvwxy{ }~ !"#$%&'()*+,-./012345678  
9:;<=>?@ABCDEFGHIJKLMNPOQRSTUVWXYZC\J^_`abcdefghijklmnopqrst  
uvwxy{ }~
```

(2) Ordinary characters with elite pitch

```
!"#$%&'()*+,-./0123456789:;<=>?@ABCDEFGHIJKLMNPOQRSTUVWXYZC\J^_`abcde  
fghijklmnopqrstuvwxy{ }~ !"#$%&'()*+,-./0123456789:;<=>?@ABCDEFGHIJKLMN  
OPQRSTUVWXYZC\J^_`abcdefghijklmnopqrstuvwxy{ }~
```

(3) Underline, subscript characters

```
!"#$%&'()*+,-./0123456789:;<=>?@ABCDEFGHIJKLMNPOQRSTUVWXYZC  
\J^_`abcdefghijklmnopqrstuvwxy{ }~
```

(4) Underline, superscript characters

```
!"#$%&'()*+,-./0123456789:;<=>?@ABCDEFGHIJKLMNPOQRSTUVWXYZC  
\J^_`abcdefghijklmnopqrstuvwxy{ }~
```

(5) Double width elongated characters

```
!"#$%&'()*+,-./0123456789:;<=  
>?@ABCDEFGHIJKLMNPOQRSTUVWXYZC  
\J^_`abcdefghijklmnopqrstuvwxy  
z{ }~
```

(6) Emphasized and double width elongated characters

```
!"#$%&'()*+,-./0123456789:;<=  
>?@ABCDEFGHIJKLMNPOQRSTUVWXYZC  
\J^_`abcdefghijklmnopqrstuvwxy  
z{ }~
```

(7) Compressed, subscript characters

```
!"#$%&'()*+,-./0123456789:;<=>?@ABCDEFGHIJKLMNOPQRSTUVWXYZ[\]^_`abcdefghijklmnopqr  
stuvwxyz{|}~
```

(8) Compressed characters

```
!"#$%&'()*+,-./0123456789:;<=>?@ABCDEFGHIJKLMNOPQRSTUVWXYZ[\]^_`abcdefghijklmnopqr  
stuvwxyz{|}~
```

(9) Compressed and elongated characters

```
!"#$%&'()*+,-./0123456789:;<=>?@ABCDEFGHI  
JKLMNOPQRSTUVWXYZ[\]^_`abcdefghijklmnopqr  
stuvwxyz{|}~
```

(10) Emphasized characters

```
!"#$%&'()*+,-./0123456789:;<=>?@ABCDEFGHIJKLMNOPQRSTUVWXYZ[\]^_`abcdefghijklmnopqr  
stuvwxyz{|}~
```

(11) Double printed characters

```
!"#$%&'()*+,-./0123456789:;<=>?@ABCDEFGHIJKLMNOPQRSTUVWXYZ[\]^_`abcdefghijklmnopqr  
stuvwxyz{|}~
```

(12) Double printed and emphasized characters

```
!"#$%&'()*+,-./0123456789:;<=>?@ABCDEFGHIJKLMNOPQRSTUVWXYZ[\]^_`abcdefghijklmnopqr  
stuvwxyz{|}~
```

2. Control codes

A CR [(0D, 8D)_H, [13, 141]_D] Carriage return

- This is the printing command. When the CR code is received, the data in the print buffer are printed.
- When there are no data in the print buffer or when only SP (space) data are contained in the print buffer, no characters are printed even upon receipt of the CR code.
- After the printing is completed, the line feed operation depends upon the AUTO FEED XT signal level or the setting of the No. 3 DIP switch.
- When data of 1 line are continuously input (in other words, when the buffer is full), printing operation does not start. When the next data are received, the data in the print buffer are printed out and a new line is fed. Thus, the data exceeding a line are printed at the top of the next line.
- "The buffer is full" (when all the character columns are full) means that 96 characters have been input in elite pitch and 80 characters in pica pitch.

B LF [(0A, 8A)_H, [10, 138]_D] Line feed

- This is the printing and line feed command; the amount of line spacing conforms to the designation.
- Upon receipt of the LF code, the data in the print buffer are printed from the start and then the paper is fed by 1 line to start a new line.
- If there are no data or only SP (space) data are contained in the print buffer, upon receipt of the LF code, the paper is fed by only 1 line. For instance, when data are input in the order of DATA→CR→LF, DATA is printed when the CR code is input. Since there are no data which precede the LF code, the printer feeds the paper by 1 line when the LF code is input.

C VT [(0B, 8B)_H, [11, 139]_D] Vertical tabulation

- This command feeds the paper to the designated line position (vertically).
- Data inside the print buffer are printed from the start upon receipt of the VT code, and after printing, the lines are fed as far as the preset designated line. When the designated tabulation position exceeds the page length, the paper is fed as far as the next top of form position.
- When no VT position has been designated or when the VT position exceeding the line being printed is not set, the data are printed and the paper is fed by 1 line (line feed) upon receipt of the VT code. The same function as LF is implemented.

D FF [(0C, 8C)_H, [12, 140]_D] Form feed

- This command feeds the paper as far as the next top of form position in accordance with the page length designation.
- Upon receipt of the FF code, the data in the print buffer are printed from the start and upon completion of the printing, the paper is fed as far as the next top of form position.
- When the page length has not been designated, 1 page is considered as having 11 inches (279.4 mm).
- Refer to the expansion functions on page 33 for the page length designation.

E HT [(09, 89)_H, [9, 137]_D] Horizontal tabulation

- This command moves the printing position as far as the designated character column position (horizontally).
- When the HT position has exceeded the maximum printing column, this command causes printing line buffer data and line feed.
- When the HT position exceeding the present character column in the buffer is not set, the printing position is not moved upon receipt of HT code.

F **SO [(0E, 8E)_H, [14, 142]_D]**
Shift out

- This command prints the doubled width elongated characters (characters which are elongated by twice their original width).
- Data after the receipt of the SO code are printed as doubled width elongated characters. This function is released by the DC4 code.
- When elongated characters and ordinary characters are mixed together in the same line, the elongated characters are converted into normal size (ordinary) characters. When the 80th character column is printed in pica pitch, this position is treated as the line end position (buffer full position).
- The elongated character designation is released in the following circumstances:
 - (a) DC4 code input...Device control 4 (elongated character release)
 - (b) When line feed has been performed.
 - (c) When the printer is initialized
Power is switched on, the $\overline{\text{PRIME}}$ signal or “ $\text{ESC} + \text{@}$ ” command is input.
- This designation is not released by input of “ $\text{ESC} + \text{W} + \text{(00)}$ ”.

G **SI [(0F, 8F)_H, [15, 143]_D]**
Shift in

- This command prints the compressed characters (characters which are compressed to half in width).
- Data after the receipt of the SI code are printed with compressed characters and this function is released by the DC2 code.
- 132 compressed characters are printed in a line with a pica pitch and 158 compressed characters with an elite pitch.
- When compressed characters and ordinary characters can be mixed together in the same line. In this case, when the printing position reaches the 80th character column of ordinary characters in pica pitch, this position is treated as the line end position (buffer full position).
- The compressed character designation is released in the following circumstances:
 - (a) DC2 code input...Device control 2 (compressed character release)
 - (b) When the printer is initialized
Power is switched on, the $\overline{\text{PRIME}}$ signal is input, or the “ $\text{ESC} + \text{@}$ ” command is received.

H **DC4 [(14, 94)_H, [20, 148]_D]**
Device control 4

- This command releases the SO operation (the double width elongated character designation)
- After receipt of the DC4 code, all data are printed out with ordinary characters.

I **DC2 [(12, 92)_H, [18, 146]_D]**
Device control 2

- This command releases the SI operation.
- After receipt of the DC2 code, all data are printed out with ordinary characters.

J **DC1 [(11, 91)_H, [17, 145]_D]**
Device control 1
(SELECT)

- This is the remote select command.
- When the DC1 code is received in the off-line mode, the printer is set to the on-line mode and data transfer from the computer is enabled. $\overline{\text{ERROR}}$ is set high, $\overline{\text{BUSY}}$ is set low and $\overline{\text{SLCT}}$ is set high, and then the $\overline{\text{ACK}}$ signal is transmitted from the printer.
- After the DC1 code is input, the line feed switch and form feed switch operations are made invalid.
- The on-line mode does not change even if the DC1 code is input in the on-line mode (the input is invalid).

K **DC3 [(13, 93)_H, [19, 147]_D]**
Device control 3 (DE-SELECT)

- This is the remote de-select command.
- When the DC3 code is received in the on-line mode, the printer is set to the off-line mode and data transfer from the computer is disabled. $\overline{\text{ERROR}}$ is set low, $\overline{\text{BUSY}}$ is set high and $\overline{\text{SLCT}}$ is set low, and then the $\overline{\text{ACK}}$ signal is not transmitted.
- After the DC3 code is input, the line feed switch and form feed switch operations are made valid.
- The off-line mode does not change even when the DC3 code is input in the off-line mode (DC3 input is invalid).

L **ESC [(1B, 9B)_H, [27, 155]_D]**
Escape

- This is the code for the expansion control command and it allows various expansion functions (see page 31 and following) to be implemented.

M **BS [(08, 88)_H, [8, 136]_D]**
Back space

- Upon receipt of this code, the data in the print buffer are printed out, and the printing position goes back by a character space to the left.
- When BS code is input twice or more continuously, the first amount of back spacing follows the character width of current character mode, but subsequent character width follows the ordinary character width.

N **DEL [(7F, FF)_H, [127, 255]_D]**
... Delete

- This clears the character received immediately before.
- Only the ordinary character codes are cleared. It is possible to clear continuously all character codes which are received into one line. However, the expansion command based on the ESC code is not cleared.

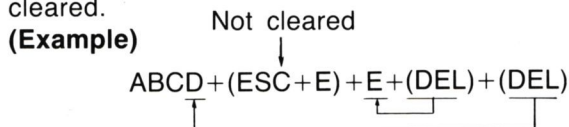

When the above has been input, "ABC" is printed. The image data, the space gap which is determined by HT code, and the character codes before these commands are not cleared.

O **BEL [(07, 87)_H, [7, 135]_D]**
... Bell

The buzzer sounds for about 0.5 second upon receipt of this code.

P **NULL [(00)_H, [0]_D]**
... Null

This is used as the termination code of both the horizontal and vertical tabulation setting sequences.

3. Expansion control commands

The following expansion functions are executed using the ESC (escape) code and the data following this code.

A **Character mode designation commands**

(1) Pica pitch designation command

$\boxed{\text{ESC}} + P [(50, D0)_H, [80, 208]_D] + \boxed{(01)}$

- Ordinary characters are printed at a pitch of 10 characters per inch or 80 characters in a line. Elongated characters are printed at 40 characters in a line. Compressed characters are printed 132 characters in a line. Superscript and subscript characters are printed 80 characters in a line.
- Any change to elite pitch in a line is ignored. After line feed, subsequent characters are printed in the designated elite pitch.

(2) Elite pitch designation command

$\boxed{\text{ESC}} + P [(50, D0)_H, [80, 208]_D] + \text{NULL}$

- Ordinary characters are printed at a pitch of 12 characters per inch or 96 characters in a line. Elongated characters are printed 48 characters in a line. Compressed characters are printed 158 characters in a line. Superscript and subscript characters are printed 96 characters in a line.
- Any change to pica pitch in a line is ignored. After line feed the characters are printed in pica pitch.

(3) Double width elongated designation command

(A) Setting command

$\boxed{\text{ESC}} + \text{W} [(57, \text{D7})_{\text{H}}, [87, 215]_{\text{D}}] + \boxed{(01)}$

- This command prints the double width elongated characters (characters whose width has been elongated to twice their original width).
- Upon receipt of this command, the subsequent data are printed in a doubled width.

(B) Release command

$\boxed{\text{ESC}} + \text{W} [(57, \text{D7})_{\text{H}}, [87, 215]_{\text{D}}]$

+NULL

- This command releases the designation of double width elongated using the " $\boxed{\text{ESC}} + \boxed{\text{W}} + \boxed{(01)}$ " command.
- The designation is not released even with line feed or receipt of the DC4 code.
- The double width elongated designation of " $\boxed{\text{SO}}$ " code is not released with this command.
- When " $\boxed{\text{ESC}} + \boxed{\text{W}} + \boxed{\text{NULL}}$ " is input in the elongated character mode designated using " $\boxed{\text{ESC}} + \boxed{\text{W}} + \boxed{(01)}$ " and " $\boxed{\text{SO}}$ ", both " $\boxed{\text{ESC}} + \boxed{\text{W}} + \boxed{(01)}$ " and " $\boxed{\text{SO}}$ " are released, so the elongated character mode is released.

(4) Emphasized character designation command

(A) Setting command

$\boxed{\text{ESC}} + \text{E} [(45, \text{C5})_{\text{H}}, [69, 197]_{\text{D}}]$

- This command prints emphasized characters [characters which are dense and are printed in superimposed printing with a shift of 1/2 dot pitch horizontally].
- Upon receipt of this command, subsequent data are printed as emphasized characters.
- The printing speed is, in this case, 40 characters/sec.
- When " $\boxed{\text{ESC}} + \boxed{\text{E}}$ " is input in the compressed character printing mode, the compressed character printing is automatically released, the ordinary characters are emphasized and they are printed.

When the release command ($\boxed{\text{ESC}} + \boxed{\text{F}}$) is input, the emphasized character is released and compressed characters are printed again.

- When " $\boxed{\text{ESC}} + \boxed{\text{E}}$ " command is input in superscript/subscript mode, emphasized characters are doubly printed out. After that, when the emphasized character mode is released, superscript/subscript characters are printed out again.

(B) Release command

$\boxed{\text{ESC}} + \text{F} [(46, \text{C6})_{\text{H}}, [70, 198]_{\text{D}}]$

- This command releases the emphasized printing mode.

(5) Double printing character designation command

(A) Setting command

$\boxed{\text{ESC}} + \text{G} [(47, \text{C7})_{\text{H}}, [71, 199]_{\text{D}}]$

- This command prints double printing characters (the paper is fed vertically by 1/288" (0.09 mm), the characters are printed twice to double the density vertically).
- Upon receipt of this command, subsequent data are printed as double printing characters.
- The characters are printed in single direction from left to right.

(B) Release command

$\boxed{\text{ESC}} + \text{H} [(48, \text{C8})_{\text{H}}, [72, 200]_{\text{D}}]$

- This is the release command for double printing designation and superscript/subscript mode.
- The single-directional printing mode involved in the superscript/subscript mode is not released.

(6) Underline designation command

(A) Setting command

`[ESC]+-[2D, AD]H, [45, 173]D+[(01)]`

- Upon receipt of this command, the underline mode is established and all subsequent input character codes are printed out with underline.
- For underlining, pin No.9 of the printing head is used. When underlining is designated to descendant character (for example "g", "y" etc.) in which pin No. 9 is used, the underline is printed out on the bottom of the character. This is normal condition.
- Image data and spaces generated by HT code are not underlined.

(B) Release command

`[ESC]+-[(2D, AD)H, [45, 173]D]`

+ NULL

- This command releases the underlining mode.

(7) Superscript/subscript mode designation command

(A) Superscript designation command

`[ESC]+ S [(53, D3)H, [83, 211]D]`

+ NULL

- Upon receipt of this command, subsequent data are printed on the top half of the line with characters reduced to 1/2 of their vertical size. [299/3810" (1.99 mm) (W)×489/9144" (1.36 mm) (H) size].

(B) Subscript designation command

`[ESC]+ S [(53, D3)H, [83, 211]D]+[(01)]`

- Upon receipt of this command, subsequent data are printed on the bottom half of the line with characters reduced to 1/2 of their vertical size. [299/3810" (1.99 mm) (W)×489/9144" (1.36 mm) (H) size].
- Both superscript and subscript printing involve double printing characters in one direction; after the first printing, the paper is fed by 1/288" (0.09 mm), the second printing is performed, and the character is formed. The paper feed is compensated for automatically so that the number of inches per page and number of lines remain as initially set.
- The font printed by superscript/subscript mode is a flat font reduced to 1/2 of its vertical size (it is not reduced horizontally). To print small characters for suffix and exponent, use superscript/subscript mode designation and compressed character command (SI code) simultaneously.

- When a character code is received after printing image data in the superscript/subscript mode, the superscript/subscript mode is released and normal characters are doubly printed out.

(C) Superscript/subscript release command

`[ESC]+ T [(54, D4)H, [84, 212]D]`

- Upon receipt of this command, the superscript/subscript mode designation is released.
- The double printing mode involved in the superscript/subscript mode is not released.
- The single-directional printing mode by "`[ESC]+ U +[(01)]`" is released.

(8) Italic mode designation command

(A) Setting command

`[ESC]+ 4 [(34, B4)H, [52, 180]D]`

- Upon receipt of this command, subsequent characters except international characters are all printed out in italic mode.

(B) Release command

`[ESC]+ 5 [(35, B5)H, [53, 181]D]`

- Upon receipt of this command, the italic mode designation is released.

B Paper feed control commands

(1) Page length designation commands

(A) Line number designation command

`[ESC]+ C [(43, C3)H, [67, 195]D]+[n]`

- This command designates the number of lines per page. This should be set in accordance with the size of the paper used and the line spacing pitch.
- The units used for the line number designation is "line", with possible designation from 1 to 127 lines. The designation itself is made in 1-byte binary form.
- The "n" greater than 127 is treated as "n-128".
- Upon receipt of this command, the size of the page length will be "n" times of the line spacing pitch which has already been designated.
- After the power has been switched on or after the `PRIME` signal or "`[ESC]+ @`" command has been received, the line spacing pitch designation command is cleared and the number of lines per page is set to 66 lines.

When $\left\{ \begin{array}{l} 1 \\ 10 \\ 100 \\ 127 \end{array} \right\}$ is designated, $\left\{ \begin{array}{l} n=01 \\ n=0A \\ n=64 \\ n=7F \end{array} \right\}$
 (Hexadecimal:
 hereafter abbreviated
 to H)

(B) Inch number designation command

$\boxed{\text{ESC}} + C [(43, C3)_H, [67, 195]_D]$

+NULL+ \boxed{m}

- This command designates the page length.
- The designation is made in inches from 1 to 22 and in 1-byte binary form. A designation of $m=00$ or $23 \leq m \leq 127$ is ignored and the previously designated setting remains effective.
- The “m” greater than 127 is treated as “m-128”.
- When a page length designation command (line number or inch number) is input, the VT setting by “ $\boxed{\text{ESC}} + \boxed{B}$ ” and skip perforation setting by “ $\boxed{\text{ESC}} + \boxed{N}$ ” are released.

(2) Line spacing pitch designation commands

(A) 1/8-inch feed command

$\boxed{\text{ESC}} + 0 [(30, B0)_H, [48, 176]_D]$

- Subsequent to receipt of this command, paper is fed at a pitch of 1/8” (3.2 mm) per line.

(B) 7/72-inch feed command

$\boxed{\text{ESC}} + 1 [(31, B1)_H, [49, 177]_D]$

- Subsequent receipt of this command, paper is fed at a pitch of 7/72” (2.47 mm) per line.

(C) 1/6-inch feed command

$\boxed{\text{ESC}} + 2 [(32, B2)_H, [50, 178]_D]$

- Subsequent to receipt of this command, paper is fed at a pitch of 1/6” (4.2 mm) per line.

- When the line spacing pitch designation is set to any value other than 1/6” (4.2 mm) feed, the line pitch is re-set to 1/6” (4.2 mm) after the PRIME signal or “ $\boxed{\text{ESC}} + \boxed{@}$ ” command has been received or after the power has been switched on.

(D) n/216-inch feed command

$\boxed{\text{ESC}} + 3 [(33, B3)_H, [51, 179]_D] + \boxed{n}$

- “n” is designated in 1-byte binary form and can be set from 1 to 255.
- The amount of paper fed per line conforms to the set value.
- The designation of $n=00$ is non-operational.

(E) n/72-inch feed command

$\boxed{\text{ESC}} + A [(41, C1)_H, [65, 193]_D] + \boxed{n}$

- “n” is designated in 1-byte binary form and can be set from 1 to 85.
- The amount of paper fed per line conforms to the set value.
- The designation of $n=00$, $86 \leq n \leq 127$ is non-operational.
- The “n” greater than 127 is treated as “n-128”.

(3) Single new line designation command

$\boxed{\text{ESC}} + J [(4A, CA)_H, [74, 202]_D] + \boxed{n}$

- This command designates single new line operation once.
- The new line pitch is designated by the (n) 1-byte binary data.
- The new line pitch unit allows setting from 0 to 255 with 1/216 inch (0.12 mm) units.
- When this command is received, the data inside the buffer are printed and new line operation is performed.
- Subsequent new line pitch returns to the value which was set before.
- The new line designation by this command does not affect the line number used in VT operation, for the line counter does not proceed.
- The “n=0” designates printing operation, but not new line.

(4) Paper end signal ignorer command

(A) Setting command

$\boxed{\text{ESC}} + 8$ [(38, B8)_H, [56, 184]_D]

- Upon receipt of this command, the signal from the out of paper detector is ignored, the $\overline{\text{ERROR}}$ signal is not output and printing can be continued.

(B) Release command

$\boxed{\text{ESC}} + 9$ [(39, B9)_H, [57, 185]_D]

- Upon receipt of this command, the out of paper end ignorer setting is released and the signal from the out of paper detector is activated.

(5) Skip perforation command

(A) Setting command

$\boxed{\text{ESC}} + N$ [(4E, CE)_H, [78, 206]_D] + \boxed{n}

- When the number of lines left on a page reaches the designated line number with the skip perforation command, the paper is fed to the top of form position on the next page.
- The number of lines left (n) is designated in 1-byte binary form and can be set from 1 to 127.
- The “ n ” greater than 127 is treated as “ $n-128$ ”.
- The designation of $n=00$ releases the skip perforation setting.
- When the amount of skip perforation (n) exceeds the page length (number of lines per page), skip perforation is executed as far as the top of form position on the next page after 1 line has been printed out.
- Even if the line spacing pitch is changed during an operation, the amount of skip perforation does not change.
- When the page length has been newly set with “ $\boxed{\text{ESC}} + \boxed{C} + \boxed{n}$ ” or with “ $\boxed{\text{ESC}} + \boxed{C} + \boxed{\text{NULL}} + \boxed{n}$ ”, the skip perforation is released.
- After the power has been switched on or after the $\overline{\text{PRIME}}$ signal or “ $\boxed{\text{ESC}} + \boxed{@}$ ” command has been received, operation conforms to the initial mode.

(B) Release command

$\boxed{\text{ESC}} + O$ [(4F, CF)_H, [79, 207]_D]

- This command releases the skip perforation setting. And the skip perforation by the DIP switch setting is also released.

(6) VT (vertical tabulation) setting command

$\boxed{\text{ESC}} + B$ [(42, C2)_H, [66, 194]_D] + $\boxed{n1}$ + $\boxed{n2}$ + ... + \boxed{nx} + NULL
($n1 < n2 < \dots < nx$, $1 \leq x \leq 12$)

- This command sets the VT (vertical tabulation) position.
- A maximum of 12 locations can be set as designated position. To designate, set the line from the top of the page in 1-byte binary form.
- Input data of more than 13 locations are processed as a standard code.
- “ n ” can be set to the maximum number of lines on a page; it can have a value of 1 to 127.

When $\left\{ \begin{array}{l} 1 \\ 10 \\ 100 \\ 127 \end{array} \right\}$ is designated, $\left\{ \begin{array}{l} n1=01 \\ n2=0A \\ n3=64 \\ n4=7F \end{array} \right.$ [H]

- The VT (0B) code should be input for executing vertical tabulation.
- The VT setting release command is as below:

$\boxed{\text{ESC}} + B$ [(42, C2)_H, [66, 194]_D]
+ NULL

The VT setting can also be released with the page length designation command

“ $\boxed{\text{ESC}} + \boxed{C} + \boxed{n}$ ” or
“ $\boxed{\text{ESC}} + \boxed{C} + \boxed{\text{NULL}} + \boxed{n}$.”

C Printing mode control commands

(1) Printing width designation command

$\boxed{\text{ESC}} + \text{Q} [(51, \text{D1})_{\text{H}}, [81, 209]_{\text{D}}] + \boxed{n}$

- The maximum printing width on one line is set according to the character size of the designated printing mode.
- The maximum printing width is fixed in each case according to the printing mode. When the value of "n" exceeds this maximum number, the designation is ignored.

Printing modes: maximum Characters per line

	Pica pitch	Elite pitch
Ordinary characters	80	96
Doubled width elongated characters	40	48
Compressed characters	132	158
Compressed and double width elongated characters	66	79
Superscript/subscript characters	80	96

- The designation is made with 1-byte binary form. A designation of n=00 is ignored and the setting immediately before remains effective.
 - When pica pitch designation command " $\boxed{\text{ESC}} + \boxed{\text{P}} + \boxed{(01)}$ " or elite pitch designation command " $\boxed{\text{ESC}} + \boxed{\text{P}} + \boxed{\text{NULL}}$ " is input, the printing width designation is released, and printing width is set to the maximum number.
 - When printing character mode is changed after the printing width has been set, printing width is kept intact. The character number which fit in the printing width are printed on one line by altered printing character mode.
- Example:**

When 60 characters printing width is designated in ordinary character mode, 30 characters are printed in one line after the mode is altered to double width elongated character.

(2) HT (horizontal tabulation) setting command

$\boxed{\text{ESC}} + \text{D} [(44, \text{C4})_{\text{H}}, [68, 196]_{\text{D}}] + \boxed{n1} + \boxed{n2} + \dots + \boxed{nx} + \text{NULL}$
 $(1 \leq n1 < n2 \dots < nx \leq 157, 1 \leq x \leq 28)$

- This command sets the HT (horizontal tabulation) position.
- A maximum of 28 locations can be set as designated position. To designate, set the second character from the beginning of the line as "1" and then designate the HT setting position with the number of characters (number of character columns) from the left edge.
- If tabs are designated in the elongated mode, the tabs are set at the positions for the ordinary characters.
- Input data of more than 28 locations are processed as a standard code.
- "n" is designated in 1-byte binary form.
 1 to 79 for ordinary characters (pica pitch)
 1 to 95 for ordinary characters (elite pitch)
 1 to 131 for compressed characters (pica pitch)
 1 to 157 for compressed characters (elite pitch)
- The values of "n" should be set ascendantly in order, starting with the smallest. Any setting of "n" exceeding the maximum printing width is ignored.
- The HT (09) code should be input for executing horizontal tabulation.
- The HT setting release command is:

$\boxed{\text{ESC}} + \text{D} [(44, \text{C4})_{\text{H}}, [68, 196]_{\text{D}}] + \text{NULL}$

(3) Single-direction printing designation command

Setting: $\boxed{\text{ESC}} + \text{U} [(55, \text{D5})_{\text{H}}, [85, 213]_{\text{D}}] + \boxed{(01)}$

Release: $\boxed{\text{ESC}} + \text{U} [(55, \text{D5})_{\text{H}}, [85, 213]_{\text{D}}] + \text{NULL}$

- Following receipt of the setting command, subsequent printing is executed such that characters are printed in one direction from left to right.
- Single-direction printing designation is suitable for graph and graphic patterns to avoid printing disarray which is caused by difference of printing direction.

(4) International character selection command

$\boxed{\text{ESC}} + \text{R} [(52, \text{D2})_{\text{H}}, [82, 210]_{\text{b}}] + \boxed{n}$
 ($0 \leq n \leq 7$)

- This command selects the country corresponding to "n" in Table 1 below. It is then possible to print the characters corresponding to the hexadecimal code in Table 2.
- The italic font cannot be selected.

Country designation (Table 1)

n	Country
0	U.S.A.
1	France
2	Germany
3	England
4	Denmark
5	Sweden
6	Italy
7	Spain

International character sets (Table 2)

Country	U.S.A.	France	Germany	England	Denmark	Sweden	Italy	Spain
Hex. code								
23	#	#	#	£	#	#	#	Pt
24	\$	\$	\$	\$	\$	¤	\$	\$
40	@	à	§	@	@	É	@	@
5B	[°	Ä	[Æ	Ä	°	í
5C	\	ç	Ö	\	Ø	Ö	\	Ñ
5D]	§	Ü]	Å	Å	é	¿
5E	^	^	^	^	^	Ü	^	^
60	·	·	·	·	·	é	ù	·
7B	{	é	ä	{	æ	ä	à	·
7C		ù	ö		ø	ö	ò	ñ
7D	}	è	ü	}	å	å	è	}
7E	~	·	ß	~	~	ü	ì	~

(5) Standard bit image designation command

$\boxed{\text{ESC}} + \text{K} [(4\text{B}, \text{CB})_{\text{H}}, [75, 203]_{\text{b}}] + \boxed{n1} + \boxed{n2}$

- This command transfers the bit image and the size (area) of the image data is expressed by "n1" and "n2".
- The data size (area) is designated by the column number. The maximum number which can be designated is 576 (equivalent to 1 line) in elite mode, and is 480 in pica mode.
- The column number is designated in 2-byte binary form with "n1" being the low-order byte and "n2" being the high-order byte.
- Only the lower 3 bits of "n2" are effective.

(Example) Column number designation

When column number $\left\{ \begin{array}{l} N=1 \\ N=2 \\ N=10 \\ N=256 \\ N=576 \end{array} \right\}$ is designated, $\left\{ \begin{array}{ll} n1=01 & n2=00 \\ n1=02 & n2=00 \\ n1=0A & n2=00 \\ n1=00 & n2=01 \\ n1=40 & n2=02 \end{array} \right.$ [H]

- When the number of columns designated is "N", data up to N bytes are received as the image data. When the transfer data exceed N bytes, remaining data received as the standard code.
- When the maximum printing width has been exceeded by a designation, the data exceeding this maximum are ignored.
- Designate the elite pitch mode in case of image printing in order to make the dot pitch ratio vertical: horizontal to 1:1.
- Upon designation of this command, that line is automatically printed by the single-direction printing.

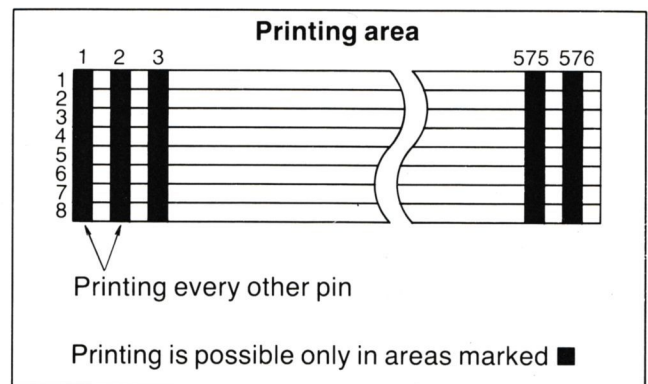

Example of data transfer when N=1

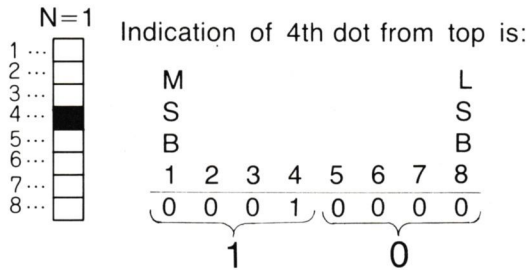

Therefore, D1=10.

Since N=1: n1=01, n2=00

From the above: $\boxed{\text{ESC}} + \boxed{\text{K}} + \boxed{\text{n1}} + \boxed{\text{n2}} + \boxed{\text{D1}}$
 $= \boxed{\text{ESC}} + \boxed{\text{K}} + \boxed{01} + \boxed{00} + \boxed{10}$

(6) Double density bit image designation command

$\boxed{\text{ESC}} + \text{L} [(4\text{C}, \text{CC})_{\text{H}}, [76, 204]_{\text{D}}] + \boxed{\text{n1}} + \boxed{\text{n2}}$

- This command transfers the double-density bit image and the size (area) of the image data is expressed by "n1" and "n2".
- The data size (area) is designated by the column number. The maximum column number which can be designated is 1152 columns (equivalent to 1 line) in elite mode, and is 960 columns in pica mode.
- The column number is designated in 2-byte binary form, with "n1" being the low-order byte and "n2" being the high-order byte.
- Only the lower 3 bits are effective.
- When the column number designation is "N", data up to N bytes are received as image data. When the transfer data exceed N bytes, remaining data are received as the standard code.
- When the maximum printing width has been exceeded by a designation, the data exceeding this maximum are ignored.
- Designate the elite pitch mode in case of image printing in order to make the dot pitch ratio vertical: horizontal to 1:1.
- Upon designation of this command, that line is automatically printed by the single-direction printing of low speed.

Printing area

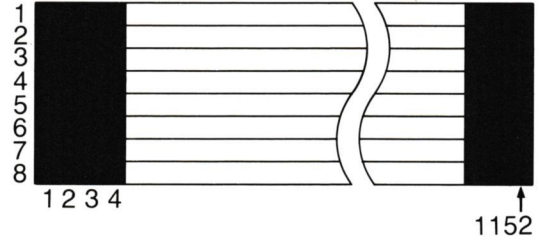

Example of data transfer when N=2

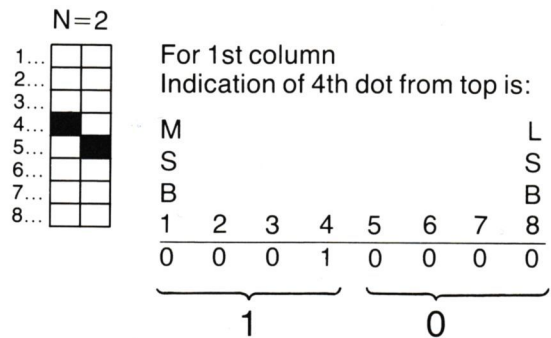

Therefore, D1=10.

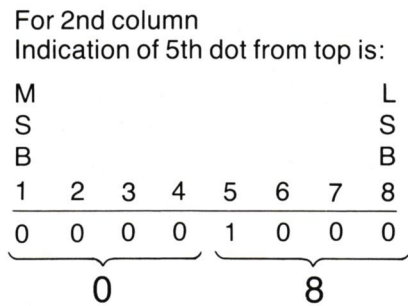

Therefore, D2=08,

Since column number N is 2: n1=02, n2=00

From the above: $\boxed{\text{ESC}} + \boxed{\text{L}} + \boxed{\text{n1}} + \boxed{\text{n2}} + \boxed{\text{D1}} + \boxed{\text{D2}}$
 $= \boxed{\text{ESC}} + \boxed{\text{L}} + \boxed{02} + \boxed{00} + \boxed{10} + \boxed{08}$

(7) Font registration command

It is possible to compile desired characters, symbols or patterns, and by registering them, to print them out.

(A) Setting command

$\boxed{\text{ESC}} + Y [(59, D9)_H, [89, 217]_B] + \boxed{\text{hexa code}} + \boxed{D1} + \boxed{D2} + \dots + \boxed{Dx} \quad (x=9)$

- Up to 62 characters can be registered (This is registration capacity).
Example:
All English capital and small letters and numbers can be displaced.
- The registration position is designated by the $\boxed{\text{hexa code}}$.
The area from location $\boxed{(20)}$ through location $\boxed{(FE)}$ can be registered (except control code position). Nine (9) byte-data subsequent to $\boxed{\text{hexa code}}$ are received as the font data.
 $\boxed{D1} + \boxed{D2} + \dots + \boxed{D9}$
- When hexa code is control code from $\boxed{(00)}$ to $\boxed{(1F)}$ or $\boxed{(7F)}$ to $\boxed{(9F)}$; All data succeeding $\boxed{\text{hexa code}}$ are processed as standard codes.
- All the characters which have been registered will be cleared when the power is switched off or when the PRIME signal or " $\boxed{\text{ESC}} + \boxed{@}$ " command is received.
- When the registered $\boxed{\text{hexa code}}$ is received, the registered, not the resident, character will be printed.

Note:

As the registered character is printed out with the half-dot pitch, please avoid to register the font that uses the same pin in succession. If a font which uses the same pin for two columns successively is registered, the bit (signal level) of the same pin on the second column is rearranged to zero and registered.

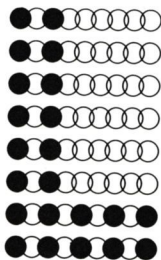

(B) Releasing command

$\boxed{\text{ESC}} + Z [(5A, DA)_H, [90, 218]_B] + \boxed{\text{hexa code}}$

- Any releasing of a registered character is possible by using $\boxed{\text{hexa code}}$ corresponding to the font which you wish to release.
- After the releasing, the housed character (resident characters) will be printed.
- It is possible to register a character to the $\boxed{\text{hexa code}}$ position which was once released.

Caution:

Avoid releasing characters that are registered, and not printed yet.
It may cause the printer to print unusual characters.

(8) MSB (Most Significant Bit) operation command

This command operates MSB included in the data which are sent from the computer. This command is effective to the 7-bit computer like the APLE. This command have preference to the setting condition of DIP switch No. 4. Only image data are not influenced by this command.

(A) MSB setting command

$\boxed{\text{ESC}} + > [(3E, BE)_H, [62, 190]_B]$

- This command sets MSB of the data at 1.

(B) MSB resetting command

$\boxed{\text{ESC}} + = [(3D, BD)_H, [61, 189]_B]$

- This command sets MSB of the data at 0.

(C) Cancel MSB operation command

$\boxed{\text{ESC}} + \# [(23, A3)_H, [35, 163]_B]$

- This command cancels the MSB operation command.
- The MSB is received in the same form as it is sent from the computer.

(9) One line Single-directional printing command

$\boxed{\text{ESC}} + < [(3C, BC)_H, [60, 188]_B]$

- Upon receipt of this command, the carriage goes left to the home position. Only the next one line is printed in single direction from left to right.

(10) Reset printer command

$\boxed{\text{ESC}} + @ [(40, C0)_H, [64, 192]_B]$

- Upon receipt of this command, all parameters in the printer are set into the default status (refer to "PRIME" on page 24)
- But mechanical errors like "overload" etc. are not reset.

(11) Undefined code

When the blank codes of the code table (see page 25, 26) are transferred, they are treated as indefinite code signals. The data are ignored.

4. Mixing printing modes/printing pitches

A Mixing printing modes

This printer is provided with a variety of printing modes. Some modes can be combined, other cannot.

	Ordinary character	Elongated	Compressed	Superscript/subscript	Double printed	Emphasized	Underline
Ordinary character		○	○	○	○	○	○
Elongated ([S0] , $\text{[ESC]} + \text{[W]}$)	○		○	*1	○	○	○
Compressed ([S1])	○	○		○	○	*3	○
Superscript/subscript ($\text{[ESC]} + \text{[S]}$)	○	*1	○		*2	*4	○
Double printed ($\text{[ESC]} + \text{[G]}$)	○	○	○	*2		○	○
Emphasized ($\text{[ESC]} + \text{[E]}$)	○	○	*3	*4	○		○
Underline ($\text{[ESC]} + \text{[]}$)	○	○	○	○	○	○	

*1 When the superscript/subscript mode and elongated mode are mixed, elongated characters are doubly printed, after that, when the elongated mode is released, superscript/subscript characters are printed out.

*2 The configuration of a character in the superscript/subscript mode is such that the paper is fed 1/288" (0.09 mm) between the first and second printings, and the character is double printed. Therefore, the double printing mode is already executed. This means that even when the double printing mode is separately established, it is ignored at the superscript/subscript character positions.

*3 When the compressed mode and emphasized mode are mixed, the compressed mode is ignored and printing is performed with the emphasized characters.

*4 When the emphasized mode and superscript/subscript mode are mixed, emphasized characters are doubly printed out, after that, when the emphasized mode is released, superscript/subscript characters are printed out.

B Mixing printing pitches

The pica and elite pitches cannot be mixed in the same line. Any change in the printing pitch is executed as designated after line spacing. The printing pitch change can be designated in a line.

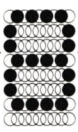

PRINTING SPEED

When modes with different speeds are mixed in the same line, that line is all printed by low speed printing mode.

- High speed printing mode 1 line/ sec.
 - Ordinary character (elite, pica)
 - Standard bit image

- Low speed printing mode 1 line/2 sec.
 - Compressed character
 - Emphasized character
 - Double density bit image

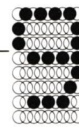

PAPER

1. Continuous paper

A list of the paper which may be used with this unit is provided below.

Width: 4~10 inches (102~254 mm) continuous paper with perforations on either side.

Quality and number of sheets: up to 3 sheets can be used; the relationship between the paper quality and number of sheets is given below.

Types of paper	Sheets	Thickness (continuous paper weight in kg)	Remarks
Fine-quality paper	1	45, 55	
Non-carbon paper	2	35, (45)	(45) for 1 copy only
	3	34, 43	
Multi-layer paper with carbon	2	30, 40 43, (55)	(55) for 1 copy only

- The multi-layer paper with carbon is such that the inserted carbon sheet is equivalent to a sheet of paper and so the maximum number of sheets of such paper is 2.
- The "continuous paper weight" represents the weight of the paper by indicating the weight of 1,000 papers [31-13/32×43-9/32 inches (798×1099 mm)] in kilograms.

A Binding

Use paper which has been stapled together at the feed perforations on both sides of the paper to bind together a multiple number of copy sheets of paper.

Note:

Try printing on the paper before proceeding, to check whether the paper can be used.

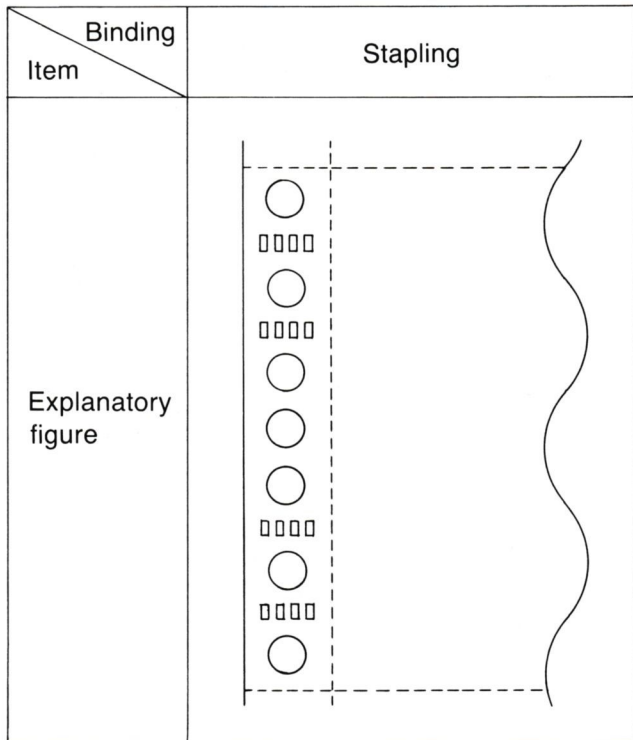

Printing should be tried out before using paper which is bound by any other method in order to check that it can be employed effectively.

B Printing area

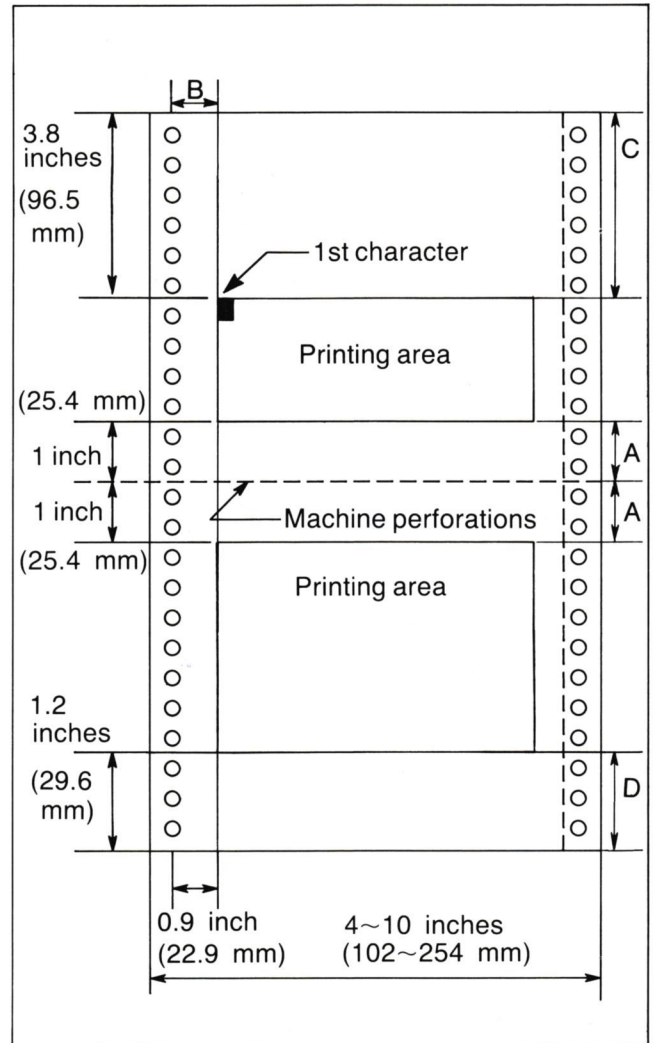

Notes:

- A: Value A indicates the positions near the machine perforations where the lines may slip.
- B: Value B indicates the position where the first character is printed. (When the left tractor is set on the left end.)
- C: Value C indicates the area from the end of the cover to the position where the first character is printed.
- D: Value D indicates the position where no more paper (7 lines remaining) is detected.

2. Letter paper

Width: 4~9 inches (102~229 mm)
 Height: 5~14.3 inches (127~363 mm)
 Thickness (paper weight in kg): 34~70 kg

Note:

Do not use transparent and semitransparent papers, because they are not detected.

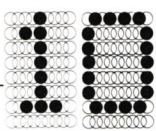

PAPER STORAGE AND MAINTENANCE

1. Paper storage

Store the paper in vinyl bags so that no moisture is absorbed and keep in a place which has a low level of humidity and which is not exposed to direct sunlight.

- If the paper is used in place where there is a great difference in the humidity, leave it for a short while before use.

2. Maintenance of unit paper

Regular cleaning is recommended for maintenance. Use a neutral detergent to wipe off the dirt on the case and covers forming the exterior parts of the printer.

(Take care not to allow the water to come into contact with the electronic components and machine parts.) Remove the wastepaper and dust internal of this unit carefully.

(Take care to the flexible cable and wiring parts of electronic.)

3. Replacement of parts

A Ribbon cassette

- (1) **Remove the front cover and top cover.**

Refer to page 8 for the removal of these covers.

- (2) **Move the printing head to the center.**

Take hold of the head carriage base when moving the printing head (refer to page 8).

Remember that the printing head is very hot immediately after a printing operation.

- (3) **Remove the ribbon cassette.**

Push the cassette holder toward the outside and lift up the cassette.

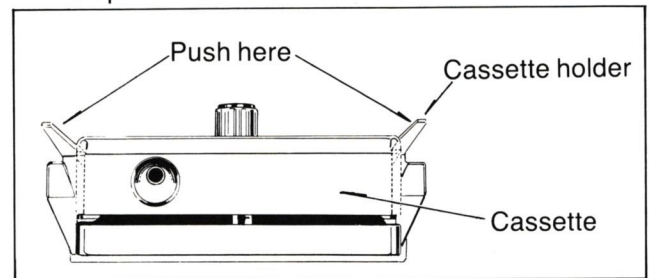

A single ribbon permits the printing of about 3 million characters. When the printing starts to fade, gently push the counter spring in the ribbon cassette hole with the tip of a ballpoint pen or other object.

Note:

Do not push this before the printing starts to fade.

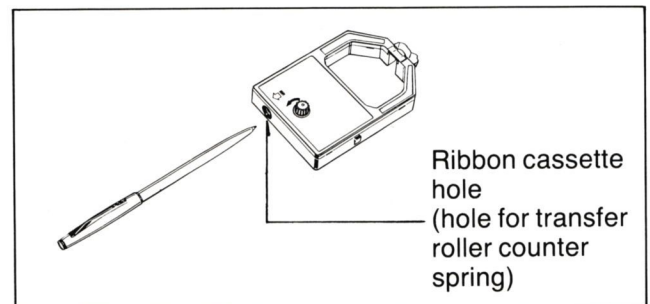

Once the ribbon cassette is mounted onto the carriage and printing is performed for a short time, the characters become thicker.

- (4) **Fresh ribbon cassette.**

When the printing starts to fade again, replace the fresh ribbon cassette.

Product name: Dot printer ribbon cassette

Product number: KX-M110

B FUSES

Fuses are provided inside the case. Ask your dealer to replace them.

Check the fuses first when the printer does not function. Always ensure that the power cord is disconnected when the fuse is checked or replaced.

(1) 1A fuse replacement procedure for serviceman

- (A) **Knob:** Pull out to remove.
- (B) **Case securing screws:** Remove the 6 screws (3 on the front panel and 3 on the rear).
- (C) **Top case:** Raise to remove.

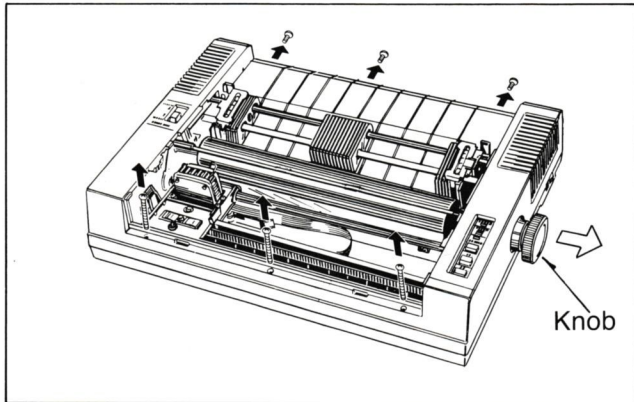

- (D) **Fuse box securing screws:** Remove the 2 screws that mount the fuse box to the main unit's bottom panel.

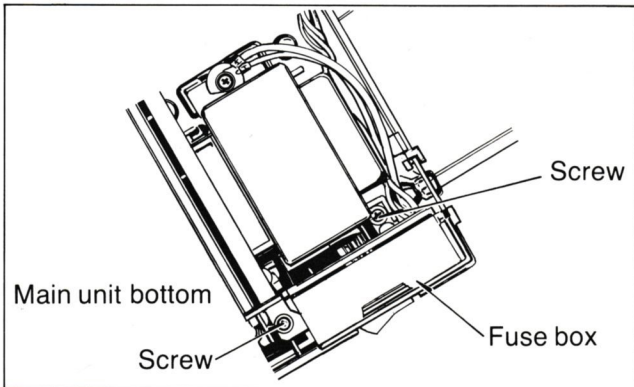

- (E) **Fuse box lid screw:** Remove the screw securing the lid of the fuse box.

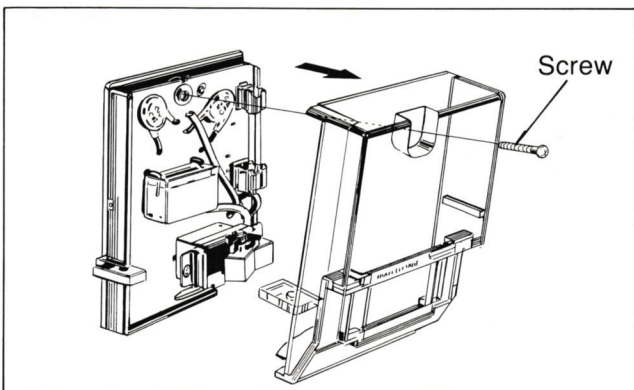

(F) Fuse replacement:

- Open the fuse box and replace the fuse. Use a 1A 250V fuse for replacement.

(2) 2.5A fuse replacement procedure

- After removing the top case, replace a 2.5A 250V fuse on the control circuit board.

C Printing head

(1) Connector disconnection

Disconnect the connector attached to the end of the flexible cable from the main unit.

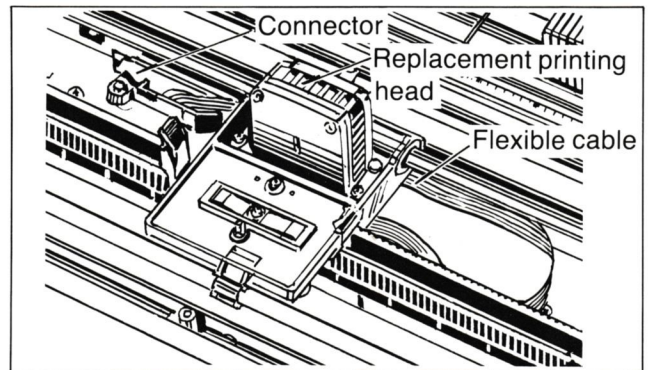

- (A) **Connector securing screw**
Remove the screw on the bottom of the main unit that secures the connector to the bottom panel.
- (B) **Connector disconnection**
Pull out the connector in the direction of ② in the figure below.

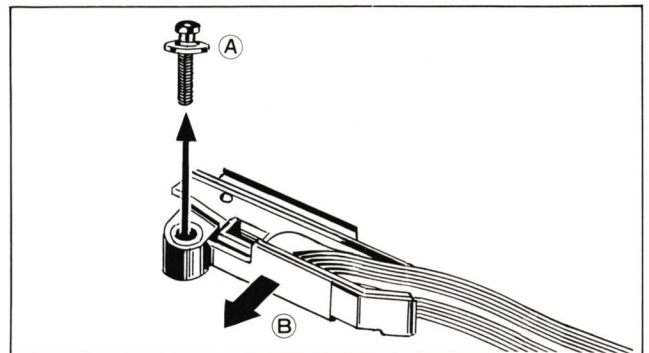

(2) Connector disassembly

Disconnect the connector attached to the end of the flexible cable from the main unit.

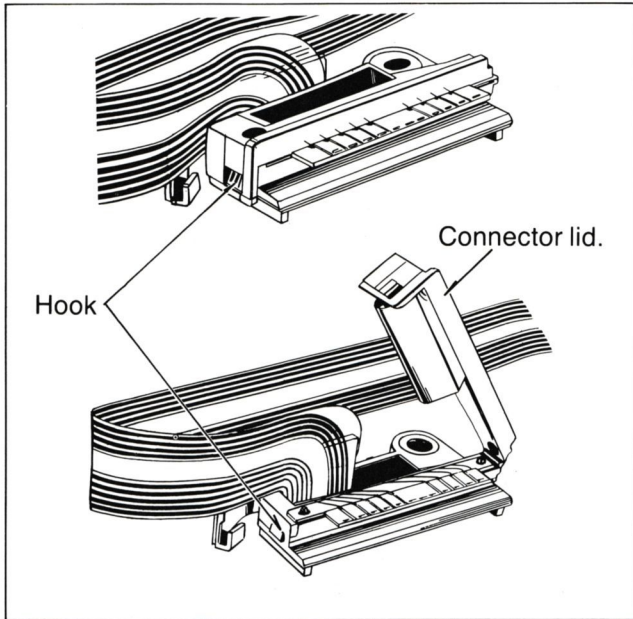

(A) To disengage the hook: Open the hook on the connector lid in the direction (A).

(B) Push the connector lid in the direction of (B) to open.

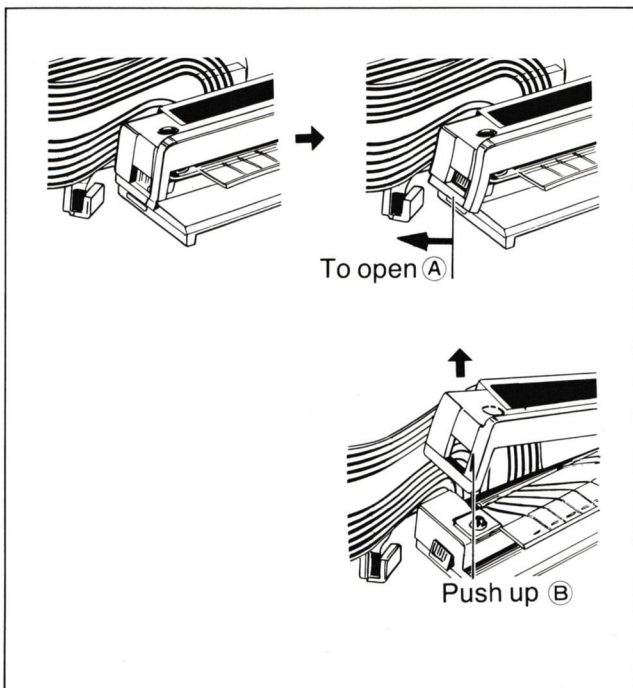

(C) Disengage the flexible cable from the two pins holding it.

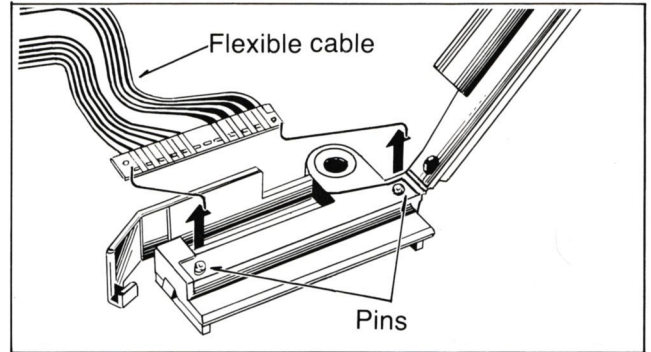

(3) Printing head section removal

(A) Printing head securing screws: Remove the 2 screws that secure the printing head.

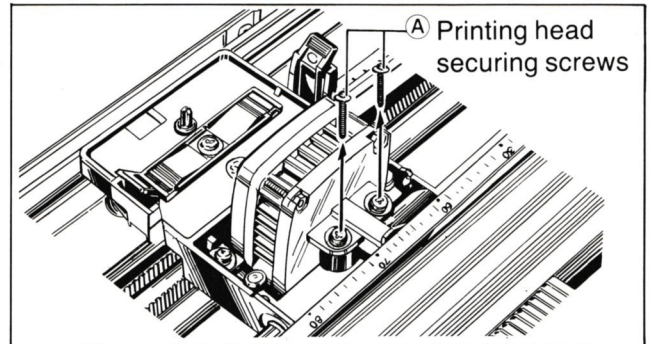

(B) The 2 screws securing the fixing plate: Remove the 2 screws in order to remove the fixing plate which is screwed to the carriage base.

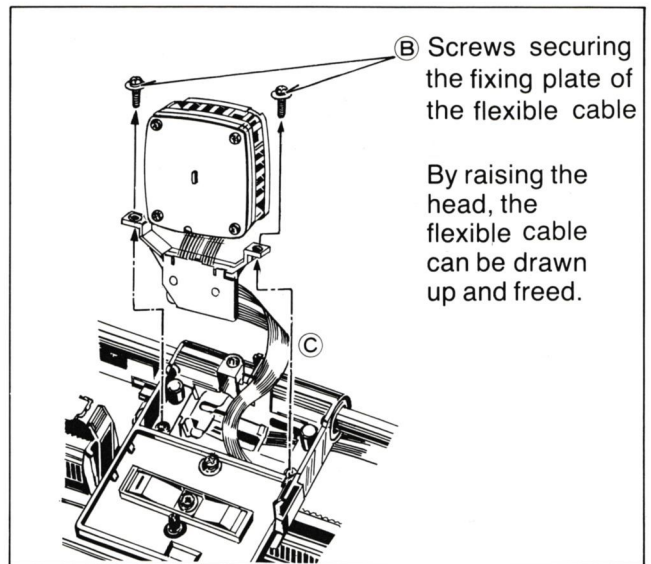

- (C) The head nose lift.
When the head is lifted, the flexible cable which is passed through the square hole in the head carriage can be drawn up and freed, and the head section can be removed from the printer.

(4) Fresh head mounting

To mount the Fresh replacement printing head, follow the procedure already mentioned in reverse.

- (A) Pull the flexible cable through the square hole in the head carriage base from its end. (Devote great care to handle of flexible cable.)
(B) Fit the head nose into place. After this, pull the head forward such that the head nose advances toward the front.

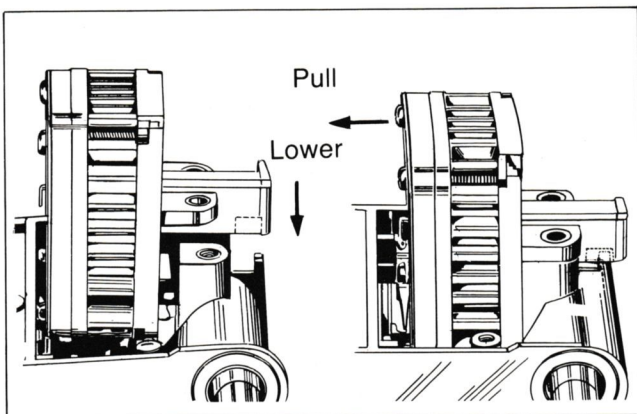

- (C) Keep the headgap between $51/127''$ (0.4 mm) and $57/127''$ (0.45 mm), and then secure the printing head nose by the 2 printing head securing screws to hold the printing head.

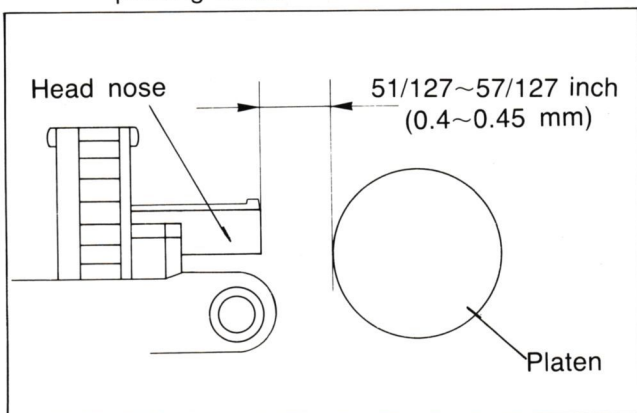

- (D) Tighten the 2 flexible cable securing fixing plate screws.
(E) Pass the 2 connector pins through the 2 holes in the flexible cable.
(F) Fit the flexible cable into position along the connector's cable guide.

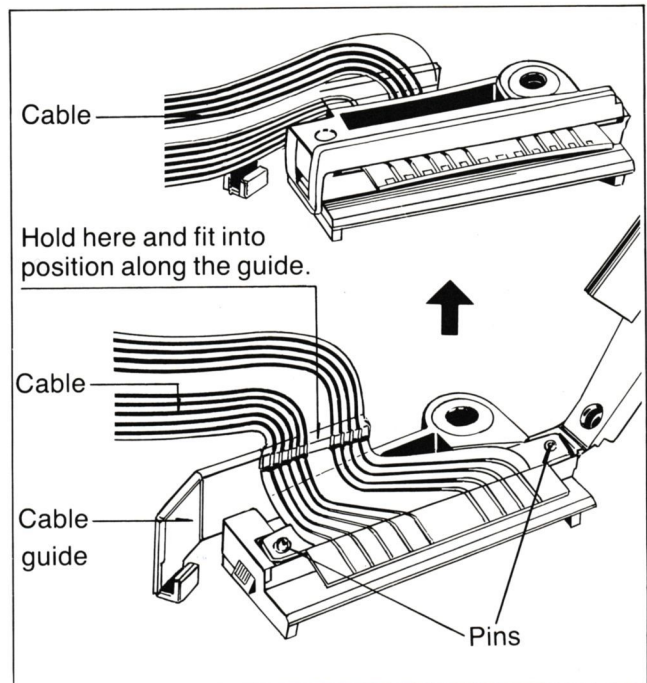

- (G) Close the connector lid and engage the hook.
(H) Connect the assembled connector to the connector socket.
(I) Tighten the connector securing screw.

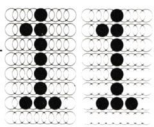

SPECIFICATIONS

Power requirements:	AC 240V (50 Hz)
Power consumption:	0.3A typ. during operation.
Fuses:	1A 250V, 2.5A 250V.
Printing system:	Impact dot matrix system
Character types:	95 ASCII characters, 11 semi graphics, 32 international characters
Dot configuration:	3/254 inch (0.3 mm) dot diameter Dot alignment: 9 horizontal dots [dot pitch of horizontal: 1/120 in. (0.212 mm)] 9 vertical dots Space: Equivalent to 3 dots [dot pitch of horizontal: 1/120 in. (0.212 mm)]
Character size	
Ordinary characters:	299/3810 (W)×435/4572 (H) in. (1.99×2.42 mm)
Superscript/subscript characters:	299/3810 (W)×489/9144 (H) in. (1.99×1.36 mm)
Number of characters per line	
Ordinary characters:	80 with pica pitch [character pitch: 1/10 in. (2.54 mm)] 96 with elite pitch [character pitch: 1/12 in. (2.12 mm)]
Double width elongated characters:	40 with pica pitch [character pitch: 1/5 in. (5.08 mm)] 48 with elite pitch [character pitch: 1/6 in. (4.23 mm)]
Compressed characters:	132 with pica pitch [character pitch: 14/240 in. (1.8 mm)] 158 with elite pitch [character pitch: 14/288 in. (1.5 mm)]
Compressed and elongated characters	66 with pica pitch [character pitch: 14/120 in. (3.6 mm)] 79 with elite pitch [character pitch: 14/144 in. (3.0 mm)]
Superscript/subscript characters:	80 with pica pitch [character pitch: 1/10 in. (2.54 mm)] 96 with elite pitch [character pitch: 1/12 in. (2.12 mm)]
Printing speed:	80 characters/sec with pica pitch } 96 characters/sec with elite pitch } Ordinary characters
Printing direction:	Ordinary characters } Semi graphics } Bi-direction Superscript/subscript characters } Bit image printing } Single-direction (left→right)
New line time:	Approx. 170 msec [with 1/6 inch (4.2 mm) line feeding]
Paper feed:	Sprocket feed (with continuous paper) Friction feed (with letter paper)
Paper used:	Continuous (Z-fold) paper: 4~10 inches (102~254 mm) wide Letter Paper: 4~9 inches (102~229 mm) wide
Number of sheets:	3 max.
Paper thickness:	Total thickness of sheets must be less than 1/100 in. (0.25 mm)
Storage environment:	-4°F (-20°C) to 140°F (60°C) temperature, 10~90% humidity
Operating environment:	41°F (5°C) to 104°F (40°C) temperature, 20~80% humidity
Head service life:	Over 50 million characters with character printing
Ribbon:	Specially designed cassette seamless ribbon Ink color: Black (one color) Service life: Approx. 3 million characters with character printing (Total life with transfer roller counter spring for ink replenishment reversed)
Dimensions:	15-43/50 (W)×11-1/4 (D)×4-53/100 (H) in. (403×286×115 mm)
Weight:	Approx. 7.0 kg

Note: Printing mode mixing

	Ordinary character designation	Elongated character designation	Compressed character designation	Superscript/subscript designation	Double printed designation	Emphasized character designation	Underline designation
Ordinary characters		○	○	○	○	○	○
Elongated characters	○		○	Elongated, double printing	○	○	○
Compressed characters	○	○		○	○	Emphasized character printing	○
Superscript/subscript characters	○	Elongated, double printing	○		Superscript/subscript character printing	Emphasized, double printing	○
Double printed characters	○	○	○	Superscript/subscript character printing		○	○
Emphasized characters	○	○	Emphasized character printing	Emphasized, double printing	○		○
Underline characters	○	○	○	○	○	○	

It is not possible to mix elite and pica pitches in the same line.

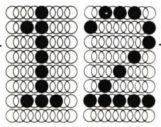

APPENDIX

(CODE TABLE, COMMAND TABLE)

1. Code table

8-bits code table

	0	1	2	3	4	5	6	7	8	9	A	B	C	D	E	F
0	NULL		SP	0	@	P	'	p			SP	0	@	P	'	p
1		DC1	!	1	A	Q	a	q	£	DC1	!	1	A	Q	a	q
2		DC2	"	2	B	R	b	r	..	DC2	"	2	B	R	b	r
3		DC3	#	3	C	S	c	s	,	DC3	#	3	C	S	c	s
4		DC4	\$	4	D	T	d	t	,	DC4	\$	4	D	T	d	t
5			%	5	E	U	e	u	§	∟	%	5	E	U	e	u
6			&	6	F	V	f	v	∟	┌	&	6	F	V	f	v
7	BEL		'	7	G	W	g	w	BEL	┌	'	7	G	W	g	w
8	BS		(8	H	X	h	x	BS	┌	(8	H	X	h	x
9	HT)	9	I	Y	i	y	HT	┌)	9	I	Y	i	y
A	LF		*	:	J	Z	j	z	LF	┌	*	:	J	Z	j	z
B	VT	ESC	+	;	K	[k	{	VT	ESC	+	;	K	[k	{
C	FF		,	<	L	\	l		FF		,	<	L	\	l	/
D	CR		-	=	M]	m	}	CR	—	-	=	M]	m	}
E	SO		.	>	N	^	n	~	SO	┌	.	>	N	^	n	~
F	SI		/	?	O	_	o	DEL	SI	┌	/	?	O	_	o	DEL

7-bits code table

	0	1	2	3	4	5	6	7	8	9	A	B	C	D	E	F
0	NULL		SP	0	@	P	'	p	NULL		SP	0	@	P	'	p
1		DC1	!	1	A	Q	a	q		DC1	!]	A	Q	a	q
2		DC2	"	2	B	R	b	r		DC2	"	2	B	R	b	r
3		DC3	#	3	C	S	c	s		DC3	#	3	C	S	c	s
4		DC4	\$	4	D	T	d	t		DC4	\$	4	D	T	d	t
5			%	5	E	U	e	u			%	5	E	U	e	u
6			&	6	F	V	f	v			&	6	F	V	f	v
7	BEL		'	7	G	W	g	w	BEL		'	7	G	W	g	w
8	BS		(8	H	X	h	x	BS		(8	H	X	h	x
9	HT)	9	I	Y	i	y	HT)	9	I	Y	i	y
A	LF		*	:	J	Z	j	z	LF		*	:	J	Z	j	z
B	VT	ESC	+	;	K	[k	{	VT	ESC	+	;	K	[k	{
C	FF		,	<	L	\	l		FF		,	<	L	\	l	
D	CR		-	=	M]	m	}	CR		-	=	M]	m	}
E	SO		.	>	N	^	n	~	SO		.	>	N	^	n	~
F	SI		/	?	O	_	o	DEL	SI		/	?	O	_	o	DEL

2. Command table

Command	Operation	Details	Ref. Page
Carriage return	CR [(0D, 8D) _H , [13, 141] _D]	Printing command	29
Line feed	LF [(0A, 8A) _H , [10, 138] _D]	Printing and new line command	29
Vertical tabulation	VT [(0B, 8B) _H , [11, 139] _D]	Line feed up to designated line	29
Form feed	FF [(0C, 8C) _H , [12, 140] _D]	Printing and paper feed up to next top of form position	29
Horizontal tabulation	HT [(09, 89) _H , [9, 137] _D]	Horizontal print position designation	29
Shift out	SO [(0E, 8E) _H , [14, 142] _D]	Double width elongated printing	30
Shift in	SI [(0F, 8F) _H , [15, 143] _D]	Printing of characters compressed to half their width	30
Device control 1	DC1 [(11, 91) _H , [17, 145] _D]	On-line mode establishment (select)	30
Device control 2	DC2 [(12, 92) _H , [18, 146] _D]	Compressed character printing release	30
Device control 3	DC3 [(13, 93) _H , [19, 147] _D]	Off-line mode establishment (de-select)	30
Device control 4	DC4 [(14, 94) _H , [20, 148] _D]	Double width elongated printing release	30
Escape	ESC [(1B, 9B) _H , [27, 155] _D]	Code for expansion control command	31
Back space	BS [(08, 88) _H , [8, 136] _D]	The data in the print buffer are printed out. The printing position goes back by one character space.	31
Delete	DEL[(7F, FF) _H , [127, 255] _D]	Clear the character received immediately before	31
Bell	BEL [(07, 87) _H , [7, 135] _D]	Buzzer sounds for approx. 0.5 sec.	31
Null	NULL [(00) _H , [0] _D]	Tab setting completion code	31

Command		Operation	Details	Ref. Page
Pica pitch designation		ESC+P [(50, D0) _H , [80, 208] _D] +(01)	Printing of 10 characters per inch. (25.4 mm)	31
Elite pitch designation		ESC+P [(50, D0) _H , [80, 208] _D] +NULL	Printing of 12 characters per inch (25.4 mm)	31
Double width elongated character designation	Setting	ESC+W [(57, D7) _H , [87, 215] _D] +(01)	Printing of characters with double width	32
	Release	ESC+W [(57, D7) _H , [87, 215] _D] +NULL	Release of double width elongated designation (No release of elongated character designation with SO code)	32
Emphasized character designation	Setting	ESC+E [(45, C5) _H , [69, 197] _D]	Superimposed printing with a shift of 1/2 dot pitch horizontally	32
	Release	ESC+F [(46, C6) _H , [70, 198] _D]	Emphasized character designation release	32
Double printed character designation	Setting	ESC+G [(47, C7) _H , [71, 199] _D]	Double printed with paper feed 1/288 inch (0.09 mm)	32
	Release	ESC+H [(48, C8) _H , [72, 200] _D]	Double printed designation release	32
Underline designation	Setting	ESC+- [(2D, AD) _H , [45, 173] _D] +(01)	Data are underlined	33
	Release	ESC+- [(2D, AD) _H , [45, 173] _D] +NULL	Underline designation release	33
Superscript designation		ESC+S [(53, D3) _H , [83, 211] _D] +NULL	Printing at top half of ordinary character printing position.	33
Subscript designation		ESC+S [(53, D3) _H , [83, 211] _D] +(01)	Printing at bottom half of ordinary character printing position	33
Superscript/subscript release		ESC+T [(54, D4) _H , [84, 212] _D]	Superscript or subscript designation release	33
Italic font designation	Setting	ESC+4 [(34, B4) _H , [52, 180] _D]	Italic font setting	33
	Release	ESC+5 [(35, B5) _H , [53, 181] _D]	Italic font release	33
Line number designation		ESC+C [(43, C3) _H , [67, 195] _D] +n	Designation of number of lines per page (1~127) n: 1-byte binary form	33
Inch number designation		ESC+C [(43, C3) _H , [67, 195] _D] +NULL +m	Designation of length per page in inches (1~22) m: 1-byte binary form	34

Command		Operation	Details	Ref. Page
Line spacing pitch designation	1/8 inch feed	ESC+0 [(30, B0) _H , [48, 176] _D]	Designation of amount of 1-line paper feed to 1/8 inch (3.2 mm) pitch	34
	7/72 inch feed	ESC+1 [(31, B1) _H , [49, 177] _D]	Designation of amount of 1-line paper feed to 7/72 inch (2.47 mm) pitch	34
	1/6 inch feed	ESC+2 [(32, B2) _H , [50, 178] _D]	Designation of amount of 1-line paper feed to 1/6 inch (4.2 mm) pitch	34
	n/216 inch feed	ESC+3 [(33, B3) _H , [51, 179] _D] +n	Designation of amount of 1-line paper feed up to 1/216~255/216 inches (0.12~29.98 mm) pitch n: 1-byte binary form	34
	n/72 inch feed	ESC+A [(41, C1) _H , [65, 193] _D] +n	Designation of amount of 1-line paper feed up to 1/72~85/72 inches (0.35~29.98 mm) pitch	34
Single new line designation		ESC+J [(4A, CA) _H , [74, 202] _D] +n	Single new line operation is performed in 1/216 inch (0.12 mm) from 0 to 255 n: 1-byte binary form	34
Paper end signal ignorer	Setting	ESC+8 [(38, B8) _H , [56, 184] _D]	Out of paper signal from paper detector ignored	35
	Release	ESC+9 [(39, B9) _H , [57, 185] _D]	Release of paper end signal ignorer designation	35
Skip perforation	Setting	ESC+N [(4E, CE) _H , [78, 206] _D] +n	Line number skipped with designation of remaining line number (1~127) n: 1-byte binary form	35
	Release	ESC+O [(4F, CF) _H , [79, 207] _D]	Release of skip perforation setting	35
VT	Setting	ESC+B [(42, C2) _H , [66, 194] _D] +n1+n2+...+nx +NULL	Presetting of line on which printing is to start and feeding paper up to designated line (1≤n1<n2...<nx≤127;1≤x≤12) n: 1-byte binary form	35
	Release	ESC+B [(42, C2) _H , [66, 194] _D] +NULL	Vertical tab setting release	35
Printing width designation		ESC+Q [(51, D1) _H , [81, 209] _D] +n	Setting of maximum printing width printed on 1 line n: 1-byte binary form	36
HT	Setting	ESC+D [(44, C4) _H , [68, 196] _D] +n1+n2+...+nx +NULL	Presetting of position at which printing is to start and skipping spaces horizontally in a line (1≤n1<n2...<nx≤157;1≤x≤28) n: 1-byte binary form	36
	Release	ESC+D [(44, C4) _H , [68, 196] _D] +NULL	Horizontal tab setting release	36
Single-direction printing designation	Setting	ESC+U [(55, D5) _H , [85, 213] _D] +(01)	Single-direction printing from left to right	36
	Release	ESC+U [(55, D5) _H , [85, 213] _D] +NULL	Single-direction printing release	36

Command		Operation	Details	Ref. Page
International character selection		ESC+ R [(52, D2) _H , [82, 210] _D] +n	Selection of characters of country corresponding to "n"	37
Standard bit image designation		ESC+ K [(4B, CB) _H , [75, 203] _D] +n1+n2	Transfer of data which can be printed every other dot horizontally; max. column number=480 in pica mode n1,n2: 2-byte binary form with n1 as low-order byte	37
Double density bit image designation		ESC+ L [(4C, CC) _H , [76, 204] _D] +n1+n2	Transfer of data which allows printing of all dots horizontally; max. column number=960 in pica mode n1, n2 : 2-byte binary form with n1 as low-order byte	38
Font registration	Setting	ESC+ Y [(59, D9) _H , [89, 217] _D] +hexa code+D1+D2+D3+ D4+D5+D6+D7+D8+D9	Command for registering new symbols, etc. (up to 62 characters can be registered) hexa code: Registration of character...(20)~(7E), (A0)~(FE) D1+D2+...D9: Font data	39
	Release	ESC+ Z [(5A, DA) _H , [90, 218] _D] +hexa code	Release of registered characters corresponding to hexa code	39
MSB Operation	Setting	ESC + > [(3E, BE) _H , [62, 190] _D]	MSB setting at 1	39
	Resetting	ESC + = [(3D, BD) _H , [61, 189] _D]	MSB setting at 0	39
	Canceling	ESC + # [(23, A3) _H , [35, 163] _D]	Canceling MSB operation	39
One line single-directional printing		ESC + < [(3C, BC) _H , [60, 188] _D]	Only one line is printed in the single-direction	39
Reset printer		ESC + @ [(40, C0) _H , [64, 192] _D]	All parameters are set into the default status.	39

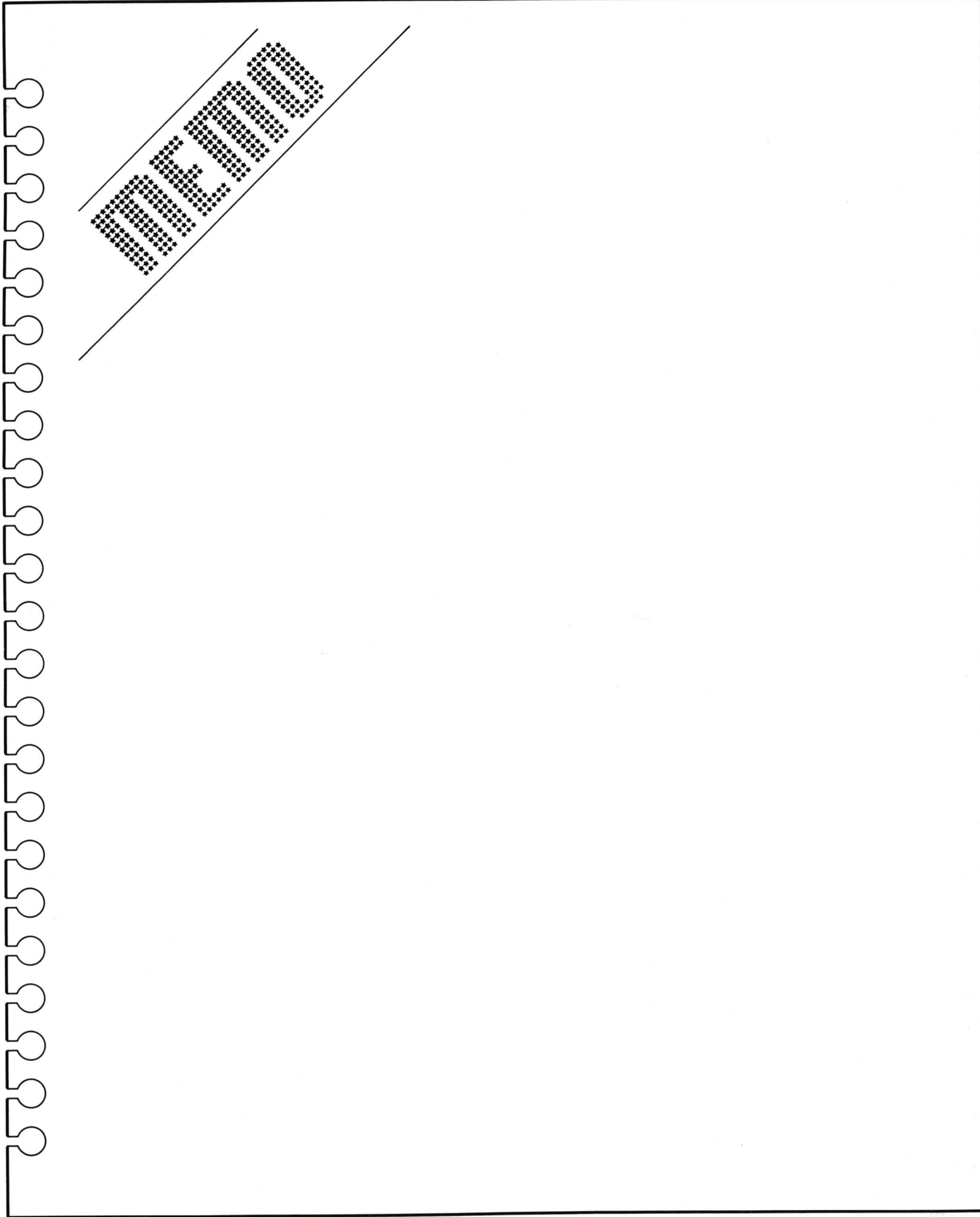

MEMOTECH LIMITED

*STATION LANE INDUSTRIAL ESTATE
WITNEY, OXON, OX8 6BX*